

CZ Obsah

1. Všeobecně.....	38
1.1 Oblast odpovědnosti provozovatele	38
1.2 Výrobce.....	38
1.3 Platné normy, schválení konstrukce.....	38
1.4 Záruka.....	38
1.5 Autorská a ochranná práva	39
1.6 Datum vydání	39
2. Údaje o produktu	39
2.1 Bestimmungsgemäßer Gebrauch.....	39
2.2 Použití v rozporu s určením.....	39
3. Bezpečnostní předpisy	40
3.1 Platné předpisy.....	40
3.2 Bezpečnostní předpisy pro montáž a využití (národními předpisy se může lišit)....	40
3.3 Bezpečnostní předpisy při pojiždění pojízdou pracovní plošinou.....	40
3.4 Prověření místa použití před montáží, po pojiždění nebo přestavbě pojízdného lešení (pojízdné pracovní plošiny)	41
3.5 Potřebné nářadí	41
4. Montáž	41
4.1 Všeobecně.....	41
4.2 Montáž stabilizační sady.....	41
4.3 Zatížení pojízdného lešení (pojízdné pracovní plošiny)	41
4.4 Po sestavení nebo změně pojízdného lešení (pojízdné pracovní plošiny).....	42
5. Demontáž pojízdné pracovní plošiny.....	42
6. Kontrola, péče a údržba.....	42
7. Přehled modelů	105
8. Součásti.....	109
9. Seznamy dílů	111
10. Shromažďovací prostory	113
11. Pracovní kroky (tabulka).....	114
12. Výkresy nástavby různých lešení.....	116
13. Podrobnosti o zátěži	128
14. Příslušenství	131

Technické změny, tiskové chyby a omyly vyhrazeny. • NADSTANDARDNÍ VYBAVENÍ a pracovní prostředky nejsou v objemu dodávky obsaženy!
Za neodborné zacházení nepřebíráme záruku. • Používat jen originální náhradní díly KRAUSE.

1. Všeobecně

Tento návod popisuje montáž a demontáž, jakož i použití pojízdného lešení (pojízdné pracovní plošiny) ProTec®. Před použitím si návod pečlivě přečtěte a seznamte se s bezpečnostními předpisy. Pojízdné lešení (pojízdná pracovní plošina smí být sestaveno, přestavováno a demontováno pouze odborně způsobilými pracovníky.

Vyhrazujeme si technické změny na pojízdném lešení (pojízdné pracovní plošině). Za tiskové chyby tohoto návodu na montáž a použití neručíme.

1.1 Oblast odpovědnosti provozovatele

Provozovatel pojízdného lešení (pojízdné pracovní plošiny) se musí postarat ve vlastní odpovědnosti o to, že:

- tento návod na sestavení a použití bude k dispozici v místě použití.
- toto pojízdné lešení (pojízdná pracovní plošina) bude používáno pouze podle tohoto návodu na montáž a použití bez jakékoliv změny.
- pojízdné lešení (pojízdná pracovní plošina) je vhodné pro práce, které se mají provést.
- provozní personál je informován o obsahu a o bezpečnostních předpisech a upozorněních na nebezpečí z tohoto návodu a pokyny a předpisy bude dodržovat.
- budou dodrženy národní, regionální a místní předpisy pro provoz pojízdného lešení (pojízdné pracovní plošiny).
- školení uživatelů není náhradou za návod na sestavení a použití a toto může pouze doplňovat.
- v některých zemích může být školení povinné.
- pojízdné lešení (pojízdná pracovní plošina) bude použita pouze dle určení.

1.2 Výrobce

Výrobce tohoto pojízdného lešení (pojízdné pracovní plošiny), které je popsáno v této dokumentaci, je firma:

KRAUSE-Werk GmbH & Co. KG

Distribuce SK:

N.K.N., s.r.o.

info@nkn-tt.sk

www.lesenie-rebriky.sk



1.3 Platné normy, schválení konstrukce

Pojízdné lešení (pojízdná pracovní plošina) série ProTec® odpovídá normě DIN EN 1004-1. Stabilita pojízdného lešení (pojízdné pracovní plošiny) a dimenzování konstrukčních dílů je prokázáno na základě statického výpočtu. Technickou kolaudaci provedl TÜV-Süd PRODUKT SERVICE (schválení konstrukce).

1.4 Záruka

Přesné znění záruky je zakotveno v prodejních a dodacích podmínkách dodavatele. Za vady materiálu přebírá výrobce záruku 5 let od data prodeje příslušného dílu. Výrobce si vyhrazuje vadný díl podle vlastního zvážení vyměnit nebo opravit.

Pro nároky na záruku z dokumentace je rozhodující návod na montáž a použití platný v den prodeje. Nárok na poskytnutí záruky je vyloučen, jestliže škody vznikly z jednoho či více následujících důvodů:

- Neznalost nebo nerespektování návodu na montáž a použití, zejména bezpečnostních pokynů, pokynů k použití dle určení, a nikoliv v rozporu s určením, pokynů k péči a údržbě, předpisů pro montáž a demontáž.
- V případě nedostatečně kvalifikovaného nebo nedostatečně informovaného provozního personálu.
- Při použití ne originálních náhradních dílů /nebo příslušenství.
- Při použití poškozených nebo vadných konstrukčních dílů.
- Zvýšení pracovní výšky použitím žebříků, beden nebo jiných zařízení.

1.5 Autorská a ochranná práva

Všechna práva k návodu na sestavení a použití má výrobce. Každý druh rozmnožování, i dílčího, je dovolen pouze se schválením výrobce. Výrobce si vyhrazuje všechna práva k udělení patentu a zápisu užitných vzorů. Protiprávní jednání zavazují k náhradě škody!

1.6 Datum vydání

Datum vydání tohoto návodu na montáž a použití je 01.11.2021.

2. Údaje o produktu

2.1 Bestimmungsgemäßer Gebrauch

Pojízdná lešení (pojízdné pracovní plošiny) uvedené v tomto návodu na montáž a použití smějí být používána podle zadání normy DIN EN 1004-1 a přehledu modelů uvedených pod bodem 7.

Pojízdné lešení (pojízdná pracovní plošina) série ProTec®-odpovídá třídě zatížení 3 (200 kg/m² plochy plošiny).



VAROVÁNÍ

před přetížením pojízdného lešení (pojízdné pracovní plošiny).
před zřícením pojízdného lešení (pojízdné pracovní plošiny), těžká nebo smrtelná zranění jsou možná.

Maximální zatížení:

- Pracovní plošina 2,00 m x 0,60 m: 240 kg; 1 osoba
- Maximální horizontální síla u plošin: 30 kg
- Pracovat se smí vždy pouze na jedné plošině.
- Výstup nahoru smí být pouze zevnitř.
- Maximální výška postavení činí 12,00 m v na všech stranách uzavřených prostorech a 8,00 m venku.
- Pojízdné lešení (pojízdná pracovní plošina) smí být postaveno pouze na dostatečně nosném a rovném základu.
- Vyrovnání musí být ověřeno vodováhou ve vertikálním i horizontálním směru. Maximálně přípustný sklon činí 1 %.
- Pojízdná lešení (pojízdné pracovní plošiny) bez výškového nastavení je třeba vyrovnat pomocí podkladů z pevného a neklouzavého materiálu.
- Před použitím je třeba zajistit, aby byla provedena všechna bezpečnostní opatření a pojízdné lešení (pojízdná pracovní plošina) bylo zřízeno podle návodu na montáž a použití.
- Pojízdné lešení (pojízdnou pracovní plošinu) je třeba případně zajistit zátěží a/nebo výložníky proti překlopení. Tabulky pro zatížení na stranách 128–130 respektovat.

2.2 Použití v rozporu s určením

Pojízdné lešení (pojízdná pracovní plošina) smí být používáno pouze pro použití dle určení uvedené pod bodem 2.1. Odchylka od tohoto ustanovení se nepovažuje za použití dle určení. V rozporu s určením je mimo jiné:

- Umístění přemostění mezi pojízdné lešení (pojízdnou pracovní plošinu) a budovu nebo okrajovou konstrukci.
- Spojování více pojízdných lešení (pojízdných pracovních plošin) do jednoho plošného, prostorového či nosného lešení.
- Použití jako schodišťovou věž k výstupu na jiné pojízdné pracovní plošiny.
- Umístění a použití zdvihacích zařízení.
- Pojízdné lešení (pojízdnou pracovní plošinu) používat jako závěsný bod pro osobní zajištění proti zřícení.
- Použití jako boční ochranu, např. na hranách zřícení.

3. Bezpečnostní předpisy

3.1 Platné předpisy

Pro montáž a demontáž, stabilitu a použití pojízdného lešení (pojízdné pracovní plošiny) platí předpisy DIN EN1004-1 a DIN EN1298 (prEN 1004-2).

3.2 Bezpečnostní předpisy pro montáž a využití (národními předpisy se může lišit)

- Montáž a demontáž, jakož i využití smí provádět pouze osoby, které se s tímto návodem seznámily.
- Pro montáž a demontáž jsou potřeba minimálně 2 osoby.
- Před montáží, přestavením nebo demontáží je třeba místo umístění zkontrolovat z hlediska možných nebezpečí. Tato nebezpečí odstranit, zabránit jim nebo je minimalizovat.
- Jako možná nebezpečí mít na paměti: nestabilní podklad, sklon, překážky, povětrnostní podmínky, nebezpečí od elektřiny, příp. zvýšená zatížení větrem tunelovým efektem u otevřených budov nebo v rozích budov.
- Používány smějí být pouze nepoškozené originální díly pojízdného lešení (pojízdné pracovní plošiny).
- Před použitím musí být pojízdné válečky zajištěny zmáčknutím brzdových páček a veškeré konstrukční díly musí být zkontrolovány z hlediska správného sestavení a funkčnosti.
- Vždy se smí pracovat pouze na jedné plošině. Ta musí mít úplnou boční ochranu pomocí prken.
- Použití pojízdného lešení (pojízdné pracovní plošiny) je přípustné pouze do síly větru 6 (~ 45 km/h). Před překročením síly větru 6 je třeba pojízdné lešení (pojízdnou pracovní plošinu) demontovat nebo s ním zajet do oblasti chráněné před větrem a tam zajistit proti překlolení.
- Překročení síly větru 6 je rozpoznatelné např. u citelného bránění při chůzi.
- Pro plošiny, na nichž se pracuje, je třeba použít 3dílnou boční ochranu sestávající ze zábradelních vzpěr, pomocných madel a oběžnými prkny. pomocných plošin, které slouží jen pro montáž, demontáž a přestavbu a výstup, může být od oběžných prken upuštěno.



- Umístění plachet nebo sítí na pojízdném lešení (pojízdné pracovní plošině) je zakázáno.
- Nelezte po vnější straně pojízdného lešení (pojízdné pracovní plošiny).
- Zvedání nebo zavěšování pojízdného lešení (pojízdné pracovní plošiny) je zakázáno.
- Externí horizontální nebo vertikální zátěže mohou vést k převrácení pojízdného lešení (pojízdné pracovní plošiny).

- Pojízdné lešení (pojízdnou pracovní plošinu) je třeba po ukončení prací ukotvit a zajistit proti nepovolanému použití, resp. demontovat.
- Traverzy a zátěžová závaží, jakož i výložníky a stabilizační sady je třeba montovat v souladu s tímto návodem na sestavení a použití.
- Nářadí a materiály smějí být nošeny pouze nahoru.
- U plošin instalovaných ve výšce nad jeden metr je přípustné použít k chůzi po plošině a pro její opuštění pouze vstupní/výstupní otvor.
- Přemostění pojízdného lešení (pojízdné pracovní plošiny) k budovám je pomocí zednické fošny nebo podobného materiálu nepřípustné.
- Pojízdné lešení (pojízdná pracovní plošina) nesmí být používána jako výstupní věž k dosažení jiných konstrukcí.

3.3 Bezpečnostní předpisy při pojiždění pojízdnou pracovní plošinou

Při pojiždění se nesmí na pojízdném lešení (pojízdné pracovní plošině) nacházet žádný materiál ani osoby.

- Pojízdné lešení (pojízdná pracovní plošina) se smí posouvat pouze ručně a pouze na pevné, rovné ploše bez překážek.
- Posouvání pojízdným lešením (pojízdnou pracovní plošinou) za pomoci jiných vozidel jakéhokoliv druhu je zakázáno.

- Při pojiždění nesmí být překročena normální kroková rychlost.
- Pojiždění smí být prováděno pouze v podélném nebo diagonálním směru.
- Plocha, na které se pojiždí, musí být na hmotnost pojižděné pracovní plošiny dimenzována.
- Zvedání nebo zavěšení pojižděného lešení (pojižděné pracovní plošiny) je zakázáno.
- Pojiždění pojižděným lešením (pojižděnou pracovní plošinou) smí být prováděno pouze do síly větru 6 (~ 45 km/h).
- Před vstupem na pojižděné lešení (pojižděnou pracovní plošinu) je třeba aretovat pojižděné válečky.

3.4 Prověření místa použití před montáží, po pojiždění nebo přestavbě pojižděného lešení (pojižděné pracovní plošiny)

Před každým použitím pojižděného lešení (pojižděné pracovní plošiny) je třeba zkontrolovat následující body:

- Pojižděné lešení (pojižděná pracovní plošina) musí stát svisle, popř. korigovat.
- Všechny díly jsou úplně montovány podle návodu na sestavení a použití.
- Zátěžová závaží a výložník jsou montovány podle návodu na sestavení a použití.
- Zajišťovací brzdy pojižděných válečků po pojiždění aretovat.
- Neexistují žádná elektrická ohrožení.
- Žádné změny životního prostředí nezabrání bezpečnému použití pojižděného lešení (pojižděné pracovní plošiny).

3.5 Potřebné nářadí

- Vodováha

4. Montáž

4.1 Všeobecně

Montáž pojižděného lešení (pojižděné pracovní plošiny) smí být prováděna až tehdy, jestliže byly kompletně přečteny údaje k produktu (oddíl 2) a bezpečnostní předpisy (oddíl 3). Pro montáž a demontáž jsou potřeba minimálně 2 osoby. Od 6 m výšky lešení je třeba na každé 2 m výšky osoba navíc. Používány smějí být pouze originální konstrukční díly podle údajů výrobce.

Na stranách 114 a 115 najdete jednotlivé pracovní kroky k montáži lešení v přehledné podobě. Respektujte prosím, že se jednotlivé pracovní kroky mohou (i několikrát) opakovat. Proto postupujte přesně podle pracovních kroků, podle výšky vašeho pojižděného lešení, které jsou od kapitoly 12 „Pracovní kroky“ podrobně zobrazeny.

* Pokud byste chtěli se sadami nepravidelných pracovních výšek (např. 7,30 m) nastavit nižší, rovné pracovní výšky (např. 6,30 m), použijte dodatečně 2 kusy diagonálních vzpěr, č. výr. 912879.

UPOZORNĚNÍ K POUŽÍVÁNÍ NÁVODU NA MONTÁŽ

Návod na montáž popisuje montáž různých variant sestavení systému ProTec®. Před montáží si kompletně přečtěte návod na montáž a respektujte rozdíly různých variant montáže. Vždy podle výšky sestavy nejhořejší plošiny jsou ke zvýšení stability potřeba zátěžová závaží (Varianta **A** – strana 125) nebo výložník (Varianta **B** – strana 126). Přečtěte si k tomu odpovídající pokyny tohoto návodu.

4.2 Montáž stabilizační sady

Při použití u stěny může převrácení proti zdi zabránit pojižděné lešení (pojižděná pracovní plošina) se stabilizační sadou. Použití stabilizační sady nenahrazuje v žádném případě předepsaná zátěžová závaží a výložník. Je třeba montovat minimálně dva kusy přímo pod nejhořejší plošinu (viz výkres strana 128). Pro zajištění ve stěně lze použít závěsný šroub.

4.3 Zatížení pojižděného lešení (pojižděné pracovní plošiny)

Pojižděná lešení (pojižděné pracovní plošiny) musí být zatíženy zátěžovými závažími na traverzách, aby se zaručila stabilita. Počet zátěžových závaží závisí na výšce pojižděného lešení (pojižděných pracovních plošin) a může být zjištěn v odpovídajících tabulkách od strany 128.

4.4 Po sestavení nebo změně pojízdného lešení (pojízdné pracovní plošiny)

Na pojízdném lešení (pojízdné pracovní plošině) musí být umístěn štítek viditelný ze země, minimálně s následujícími informacemi:

- jméno a kontaktní údaje odpovědné osoby
- zda je pojízdné lešení (pojízdná pracovní plošina) připravena k použití nebo ne
- třída zatížení a maximálně rovnoměrně rozdělená celková zátěž
- zda je pojízdné lešení (pojízdná pracovní plošina) určena jen k použití v uzavřených prostorách
- datum montáže

5. Demontáž pojízdné pracovní plošiny

Pojízdná lešení (pojízdné pracovní plošiny) se demontují v obráceném pořadí příslušného popisu pro montáž.

6. Kontrola, péče a údržba



Před montáží je třeba všechny díly zkontrolovat z hlediska poškození a při poškození vyměnit. Opravy dílů smějí být prováděny pouze výrobcem. Používat se smějí jen originální náhradní díly.

Vizuální kontrolou musí být zaručeno, že svary a jiné materiály nevykazují žádné trhliny. Dále nesmějí mít díly žádné deformace a zmáčknutí. Je třeba bezpodmínečně dbát na bezvadnou funkci konstrukčních dílů, jako blokovací mechanismy, šrouby, pojízdné válečky atd.

Před každou montáží je třeba zkontrolovat následující díly:

- Vertikální rámy, pojízdné traverzy: z hlediska deformace, zmáčknutí, tvorby trhlin
- Diagonální a zábradelní vzpěry: z hlediska deformace, zmáčknutí, tvorby trhlin a funkce bezpečnosti
- Plošiny: z hlediska deformace, zmáčknutí, tvorby trhlin a funkce bezpečnosti
- Průchozí otvor: z hlediska funkce
- Prkna: stav dřeva, trhliny
- Řídící válečky: schopnost otáčení válečku a funkce brzdy z hlediska zábrany pojezdu a otáčení.
- U nastavitelných válečků lehkost chodu šroubů. Zabezpečení proti vypadnutí (zástrčky, šrouby s křídlovou hlavou u vertikálních ráků, resp. pojízdné traverzy
- Zajištění proti vytažení: z hlediska deformace, zmáčknutí, tvorby trhlin a správného usazení
- Díly musí být skladovány tak, aby byla vyloučena poškození.
- Jednotlivé díly musí být skladovány položené a chráněné před povětrností.
- Díly musí být při transportu položeny a zajištěny tak, aby se zabránilo poškozením.
- Čištění dílů může být prováděno vodou a běžným čisticím prostředkem. Znečištění barvou mohou být odstraněna terpentýnem.

7.

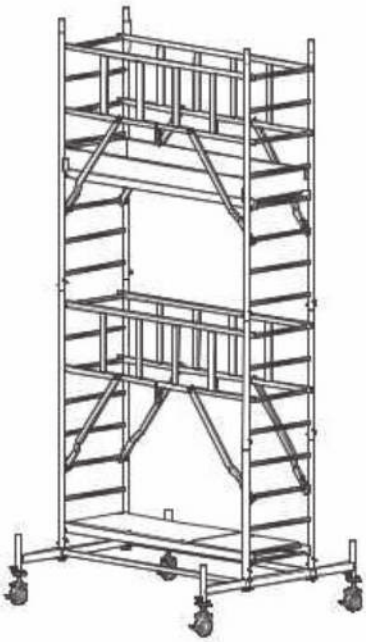
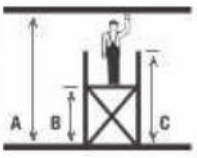
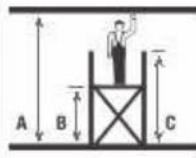
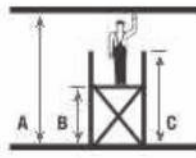
Art.-No.	940100	Art.-No.	940117	Art.-No.	940124																		
																							
	<table border="1"> <tr> <td>A</td> <td>2,90 m</td> </tr> <tr> <td>B</td> <td>0,90 m</td> </tr> <tr> <td>C</td> <td>2,35 m</td> </tr> </table>	A	2,90 m	B	0,90 m	C	2,35 m		<table border="1"> <tr> <td>A</td> <td>4,30 m</td> </tr> <tr> <td>B</td> <td>2,30 m</td> </tr> <tr> <td>C</td> <td>3,45 m</td> </tr> </table>	A	4,30 m	B	2,30 m	C	3,45 m		<table border="1"> <tr> <td>A</td> <td>5,30 m</td> </tr> <tr> <td>B</td> <td>3,30 m</td> </tr> <tr> <td>C</td> <td>4,45 m</td> </tr> </table>	A	5,30 m	B	3,30 m	C	4,45 m
A	2,90 m																						
B	0,90 m																						
C	2,35 m																						
A	4,30 m																						
B	2,30 m																						
C	3,45 m																						
A	5,30 m																						
B	3,30 m																						
C	4,45 m																						

Art.-No. 940131

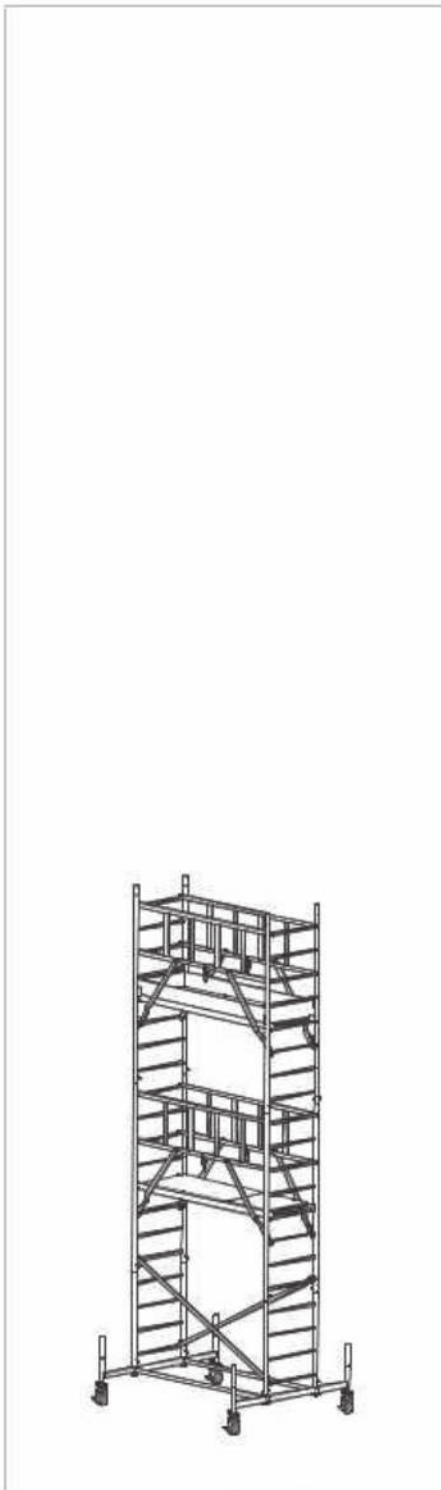

	A	6,30 m
	B	4,30 m
	C	5,45 m

Art.-No. 940148

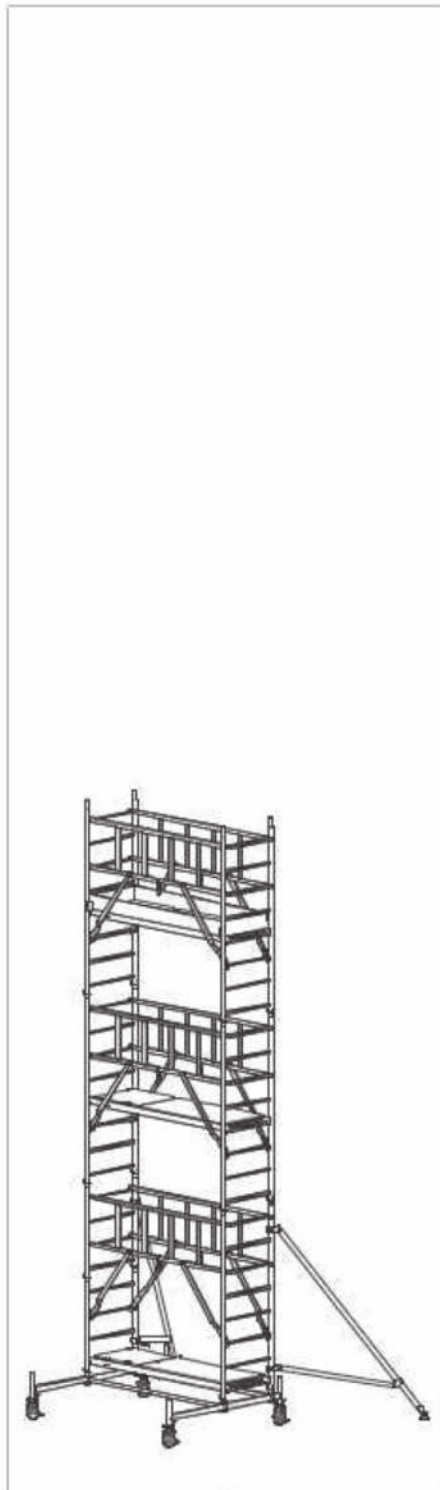

	A	7,30 m
	B	5,30 m
	C	6,45 m

Art.-No. 940155

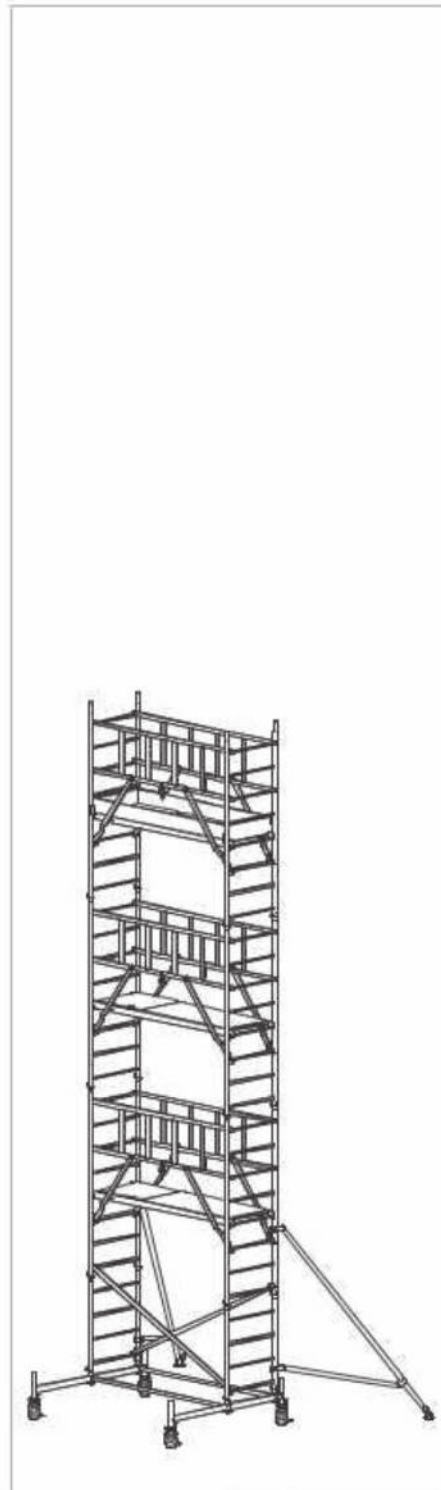

	A	8,30 m
	B	6,30 m
	C	7,45 m

Art.-No.	940162
-----------------	---------------

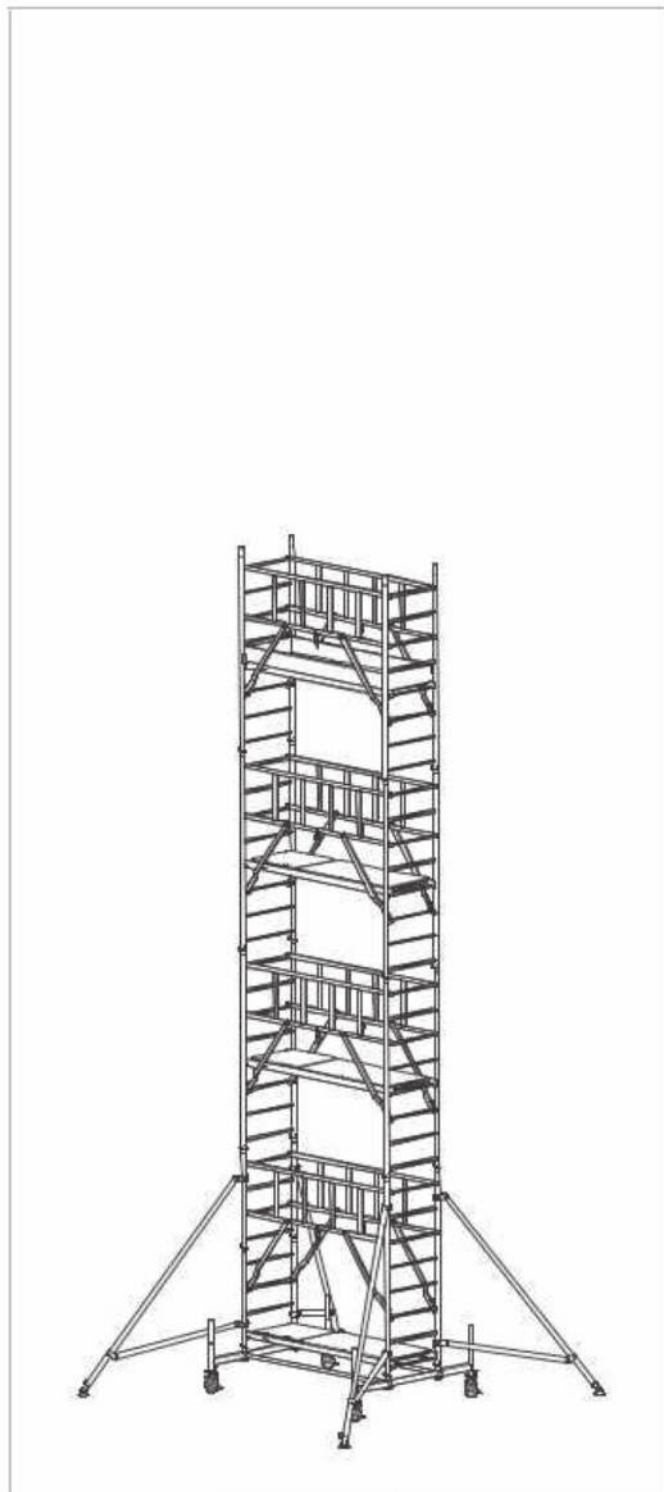

	A	9,30 m
	B	7,30 m
	C	8,45 m

Art.-No.	940179
-----------------	---------------

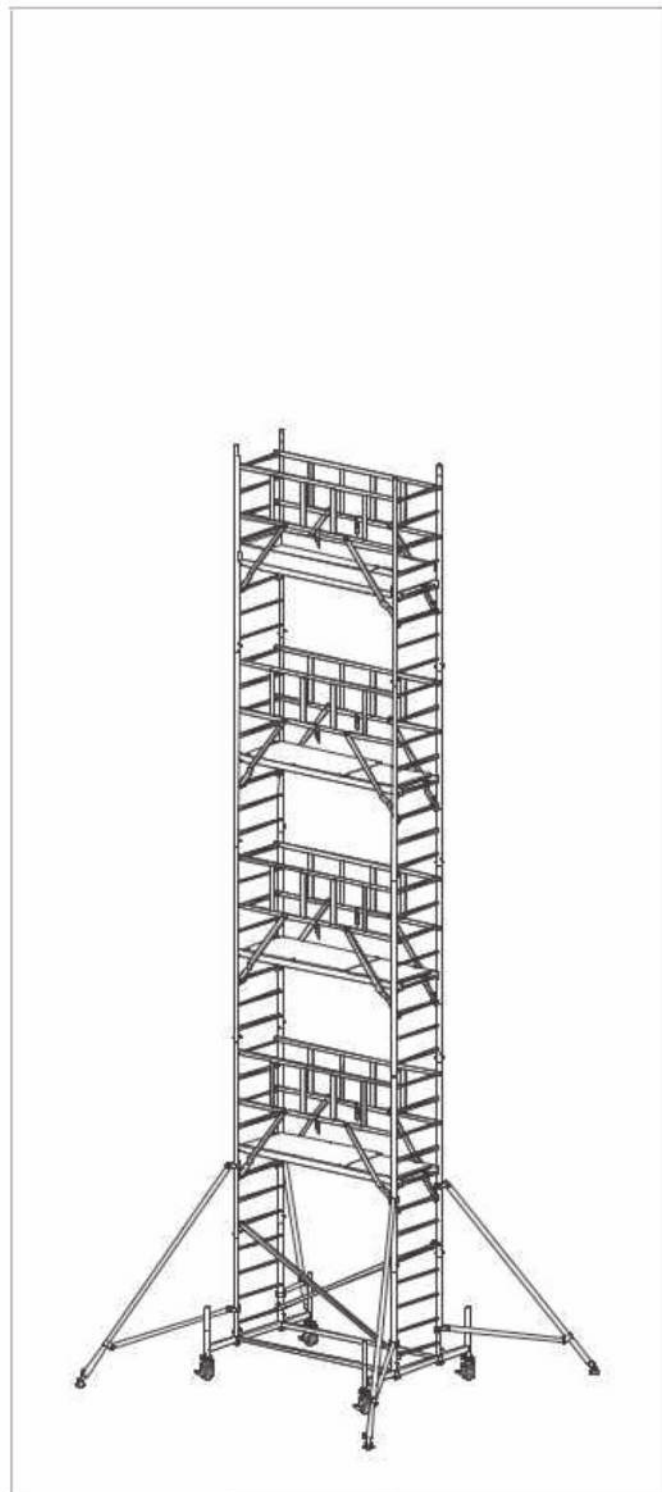

	A	10,30 m
	B	8,30 m
	C	9,45 m

Art.-No. 940186

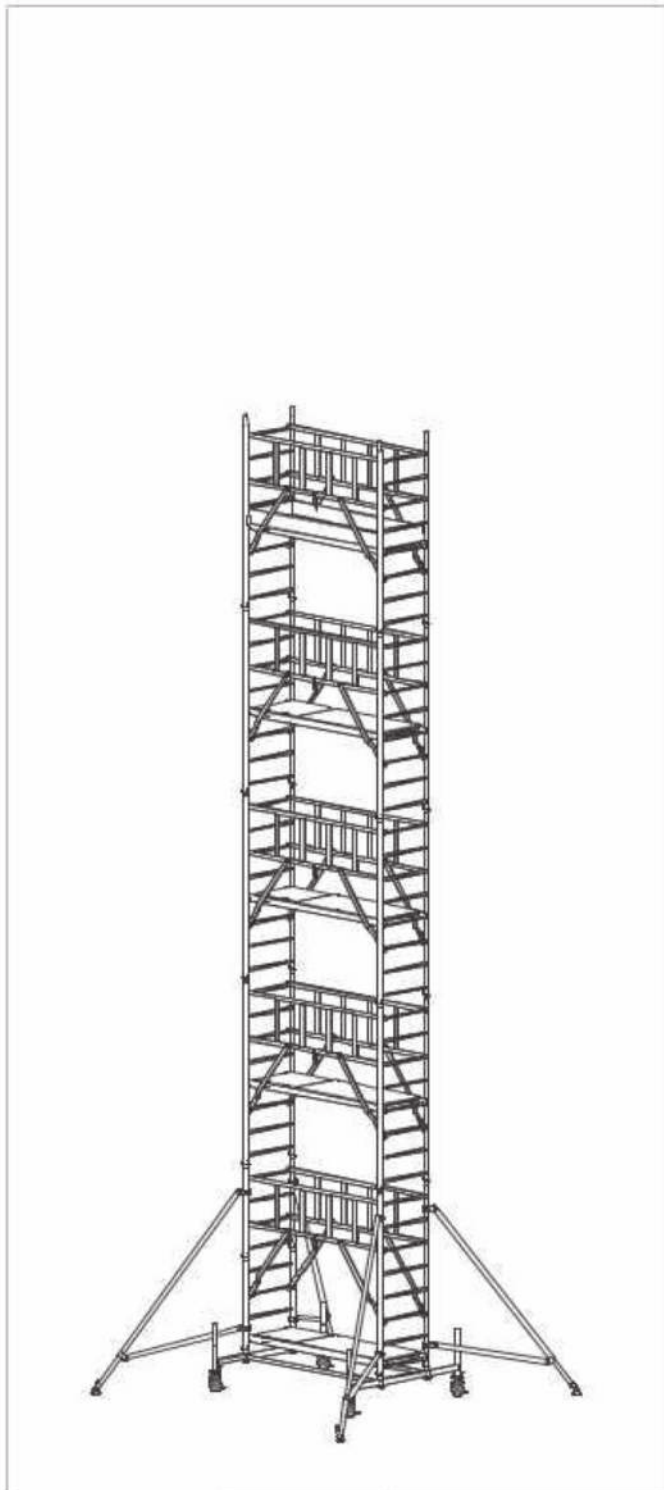





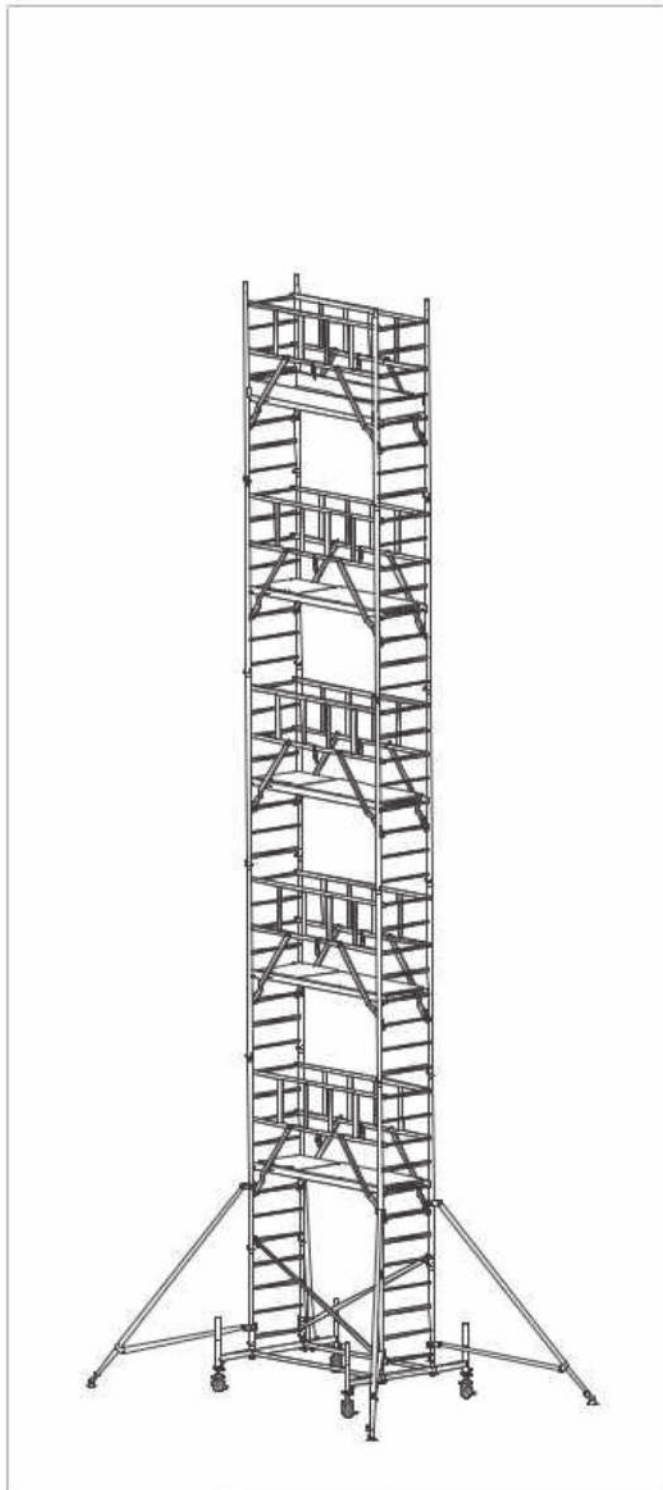



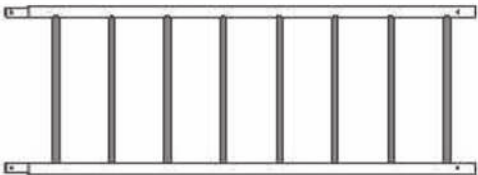
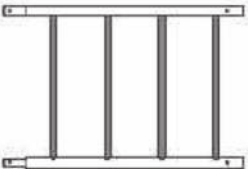
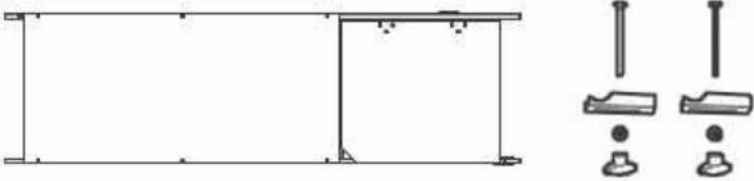

	A	11,30 m
	B	9,30 m
	C	10,45 m

Art.-No. 940193







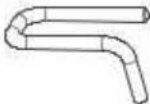



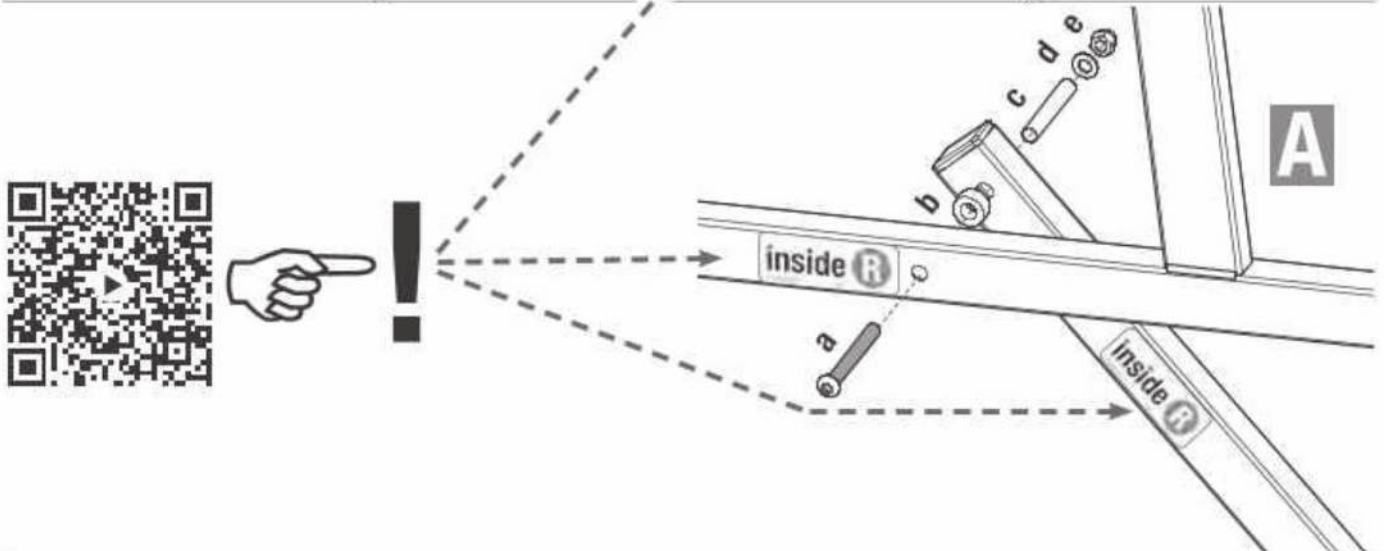
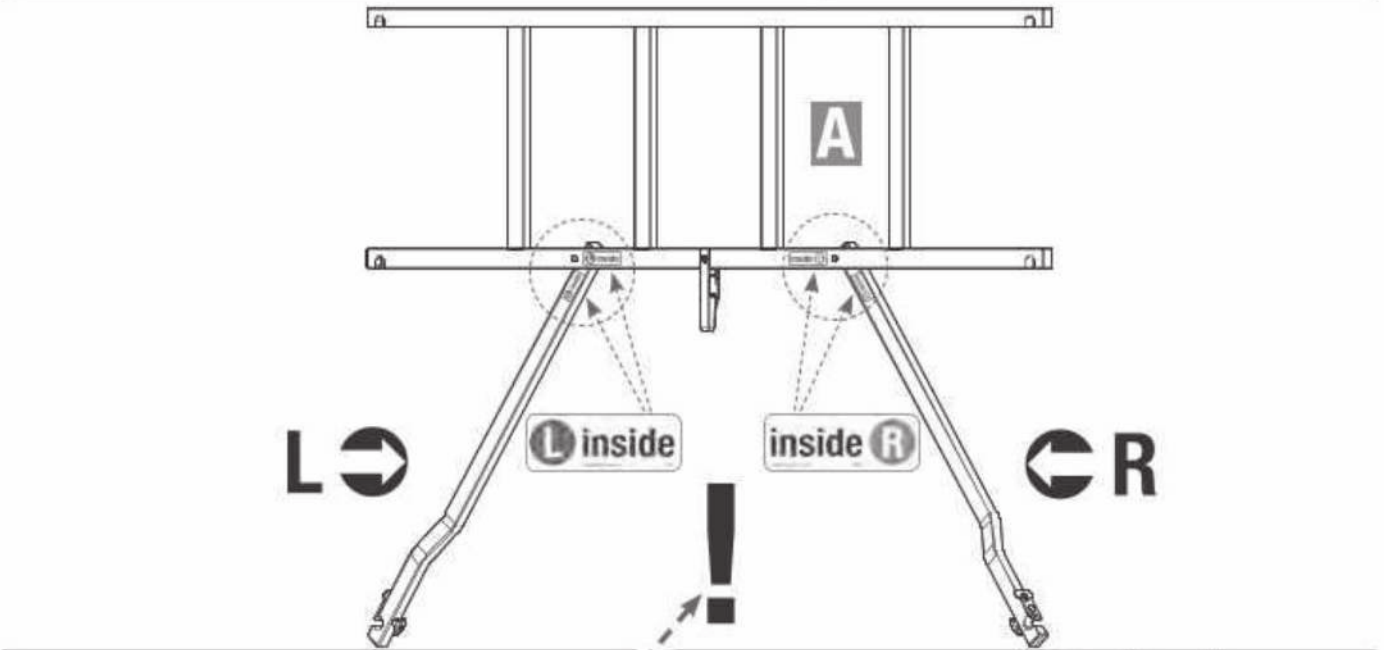
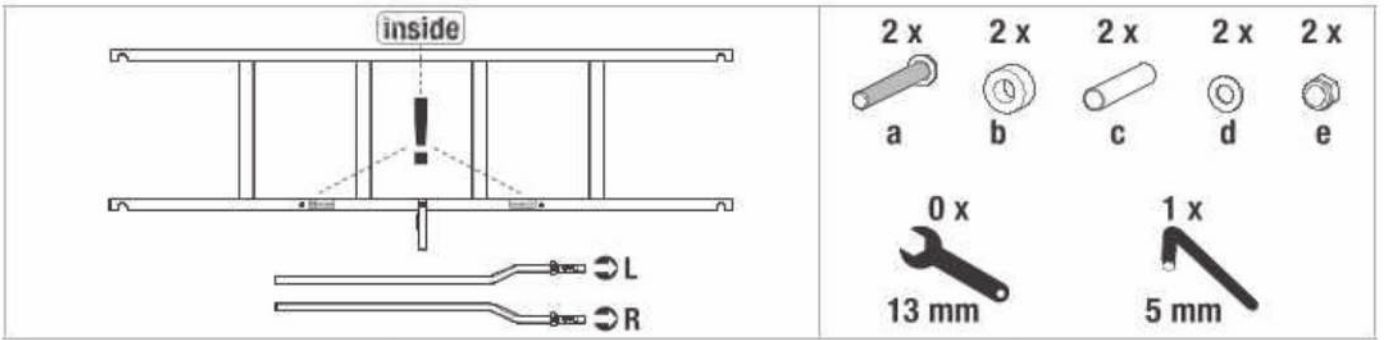

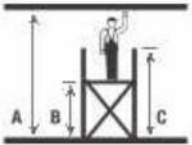
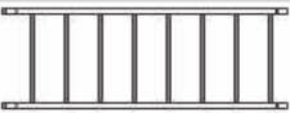
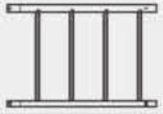

	A	12,30 m
	B	10,30 m
	C	11,45 m

8.

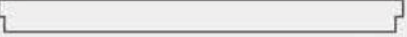



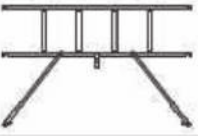





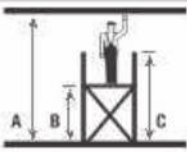
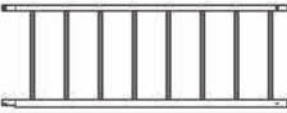

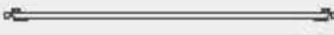
	<p>Art.-No. 915016</p>				
	<p>Art.-No. 915023</p>				
	<p>Art.-No. 911001</p>				
	<p>Art.-No. 912879</p>				
	<p>Art.-No. 912855</p>				
	<p>Art.-No. 912848</p>				
	<p>Art.-No. 914071</p>				
	<p>Art.-No. 913555</p>				
	<p>Art.-No. 913517</p>				
	<p>Art.-No. 914095</p>				
	<p>Art.-No. 910073</p>				
	<p>Art.-No. 914118</p>		<p>Art.-No. 914026</p>		<p>Art.-No. 704405</p>

Art.-No. 910073



9.	Art.-No.						kg	
		A	940100	940117	940124	940131		940148
		B	2,90 m	4,30 m	5,30* m	6,30 m		7,30* m
		C	0,90 m	2,30 m	3,30 m	4,30 m		5,30 m
C	2,35 m	3,45 m	4,45 m	5,45 m	6,45 m			
Art.-No.								
915016		2	2	3	4	5	5,3	
915023		0	2	2	2	2	2,7	
911001		1	1	2	2	3	13	
912855		1	0	0	0	0	1,2	
912848		0	2	2	2	2	5,0	
914071		0	2	2	2	2	6,5	
913555		0	2	2	2	2	0,8	
913517		0	2	2	2	2	2,8	
914095		0	0	0	0	2	8,0	
914118		4	4	4	4	4	3,8	
914026		4	4	4	4	4	0,6	
704405		4	8	10	12	14	0,1	
910073		0	2	4	4	6	3,3	
912879		1	2	0*	2	0*	1,5	
Σ kg		45,0	89,0	115,0	123,0	159,0		

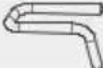
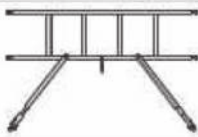

Art.-No.		940155	940162	940179	940186	940193		
		A	8,30 m	9,30* m	10,30 m	11,30* m	12,30 m	
		B	6,30 m	7,30 m	8,30 m	9,30 m	10,30 m	
		C	7,45 m	8,45 m	9,45 m	10,45 m	11,45 m	
Art.-No.							kg	
915016		6	7	8	9	10	5,3	
915023		2	2	2	2	2	2,7	
911001		3	4	4	5	5	13	
912855		0	0	0	0	0	1,2	
912848		2	2	2	2	2	5,0	
914071		2	2	2	2	2	6,5	
913555		2	2	2	2	2	0,8	
913517		2	2	2	2	2	2,8	
914095		2	4	4	4	4	8,0	
914118		4	4	4	4	4	3,8	
914026		4	4	4	4	4	0,6	
704405		16	18	20	22	24	0,1	
910073		6	8	8	10	10	3,3	
912879		2	0*	2	0*	2	1,5	
Σ kg		177,0	203,0	211,0	237,0	245,0		

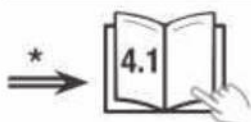

10.

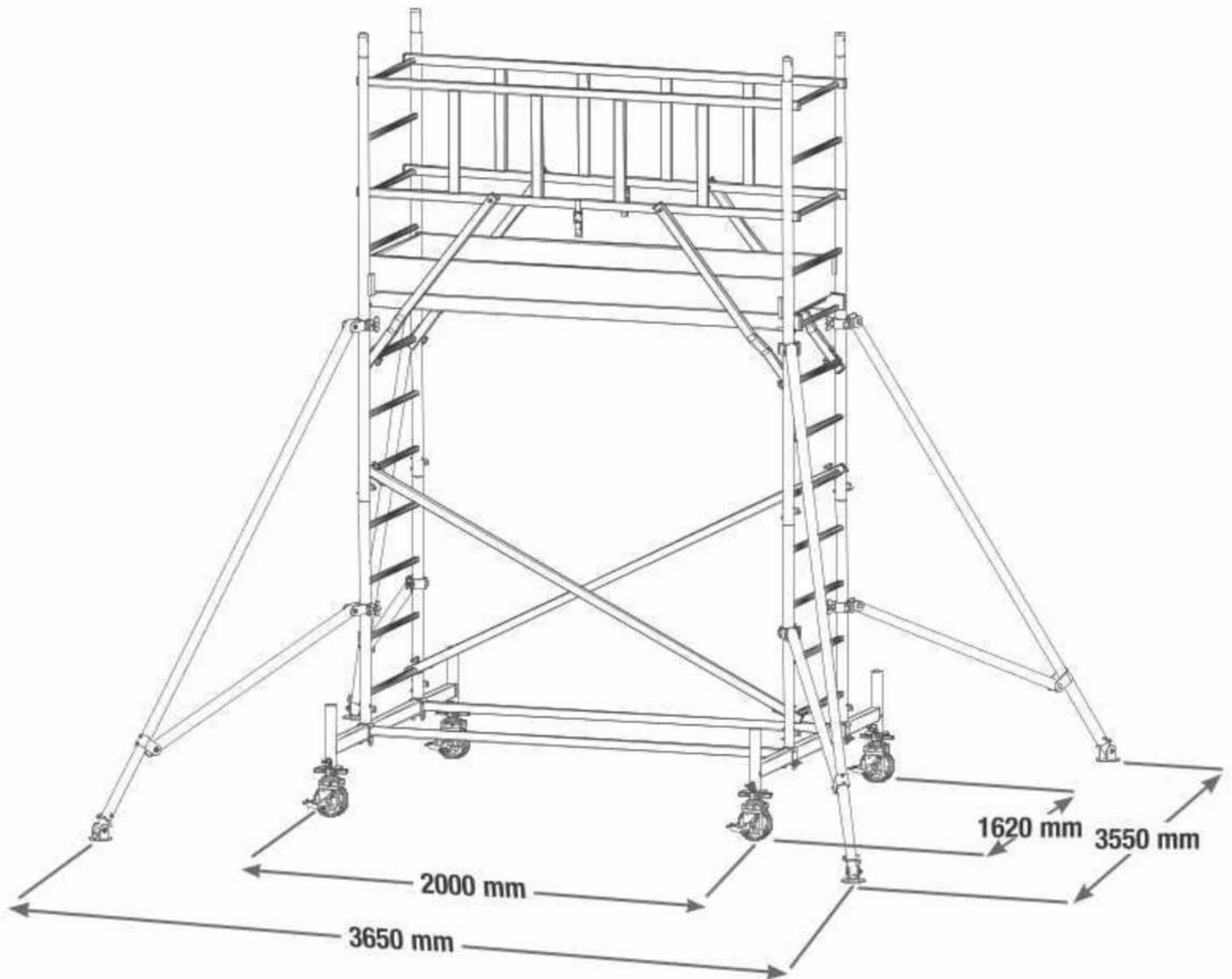



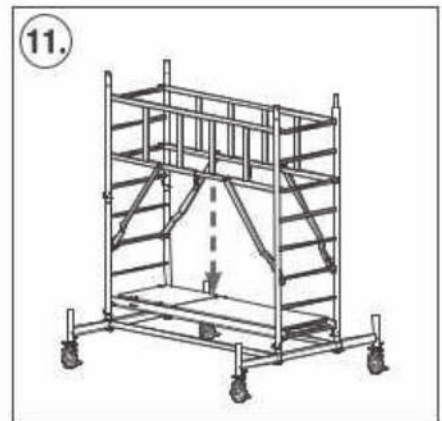
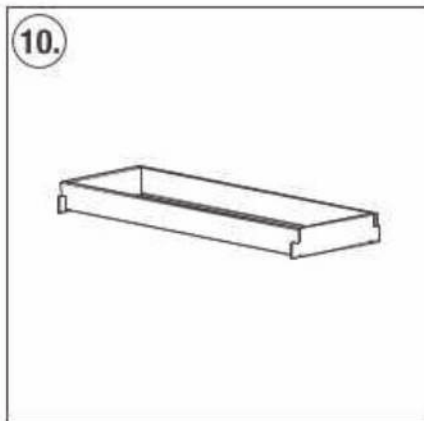
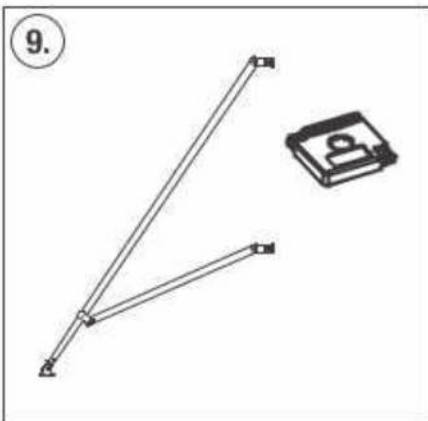
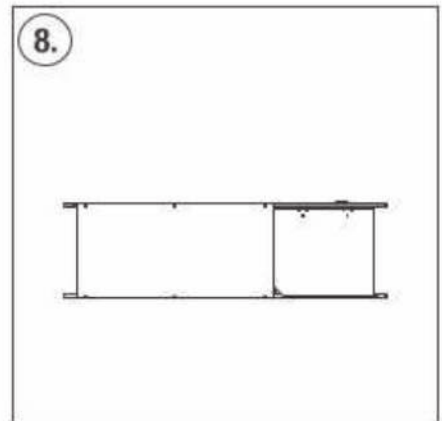
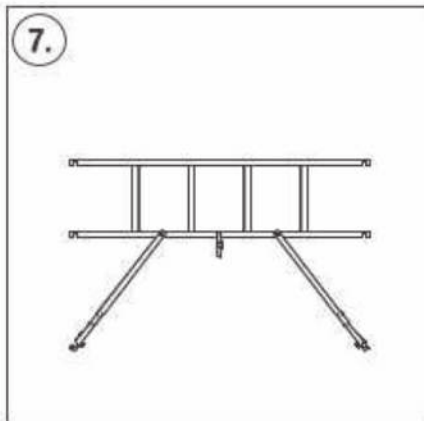
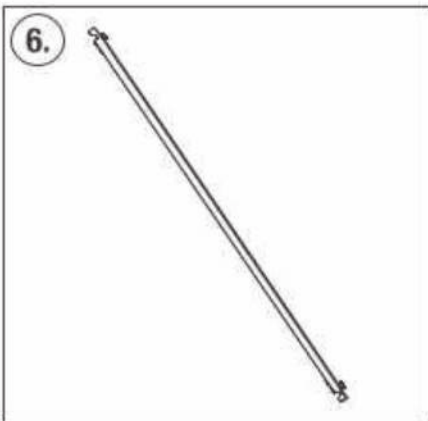
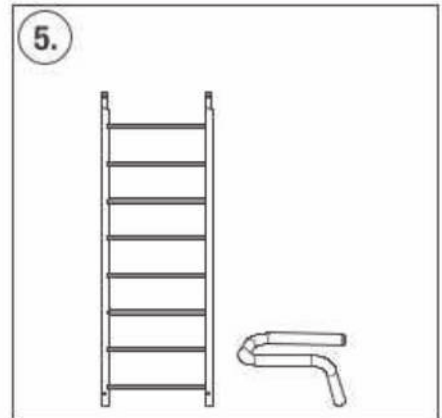
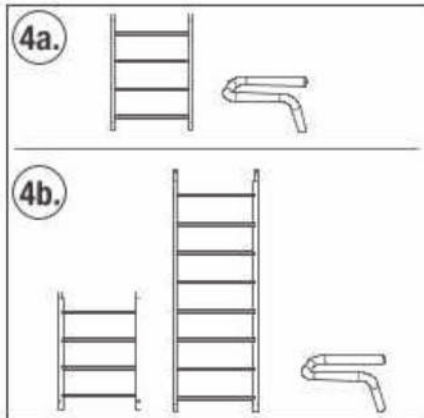
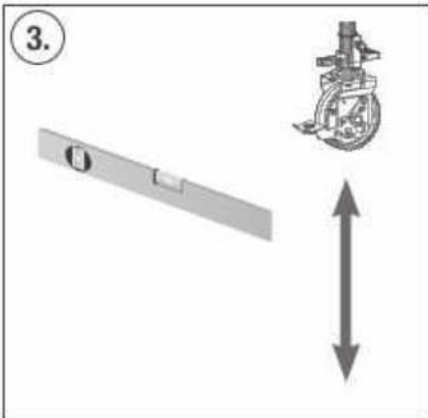
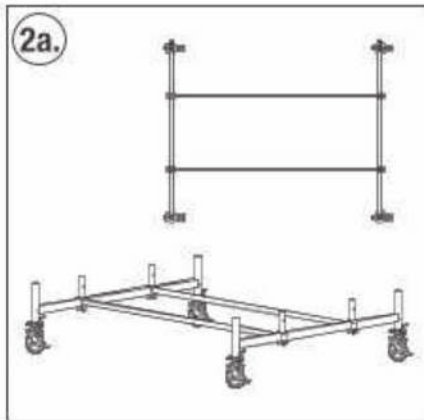

11.





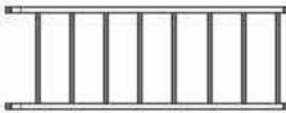

Art.-No.		
940100	2,90 m	= 1.
940117	4,30 m	= 2a. + 3. + 4a. + 5. + 6. + 7. + 8. + 9. + 10.
940124	5,30 m	= 2a. + 3. + 4b. + 7. + 8. + 9. + (5. + 7. + 8.) + 10. + 11.
940131	6,30 m	= 2a. + 3. + 4a. + 5. + 6. + 7. + 8. + 9. + (5. + 7. + 8.) + 10.
940148	7,30 m	= 2b. + 3. + 4b. + 7. + 8. + 9. + (5. + 7. + 8.) + (5. + 7. + 8.) + 10. + 11.
940155	8,30 m	= 2b. + 3. + 4a. + 5. + 6. + 7. + 8. + 9. + (5. + 7. + 8.) + (5. + 7. + 8.) + 10.
940162	9,30 m	= 2a. + 3. + 4b. + 7. + 8. + 9. + (5. + 7. + 8.) + (5. + 7. + 8.) + (5. + 7. + 8.) + 10. + 11.
940179	10,30 m	= 2a. + 3. + 4a. + 5. + 6. + 7. + 8. + 9. + (5. + 7. + 8.) + (5. + 7. + 8.) + (5. + 7. + 8.) + 10.
940186	11,30 m	= 2a. + 3. + 4b. + 7. + 8. + 9. + (5. + 7. + 8.) + (5. + 7. + 8.) + (5. + 7. + 8.) + (5. + 7. + 8.) + 10. + 11.
940193	12,30 m	= 2a. + 3. + 4a. + 5. + 6. + 7. + 8. + 9. + (5. + 7. + 8.) + (5. + 7. + 8.) + (5. + 7. + 8.) + (5. + 7. + 8.) + 10.



	2 x Art.-No. 915016
	1 x Art.-No. 911001
	1 x Art.-No. 912879
	1 x Art.-No. 912855

	4 x Art.-No. 914026
	4 x Art.-No. 914118

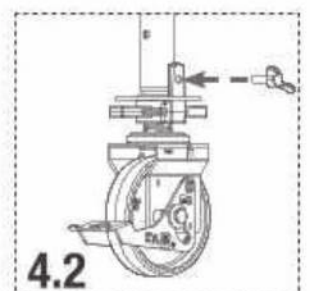
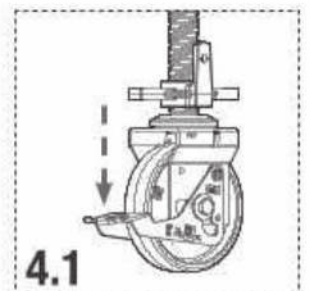
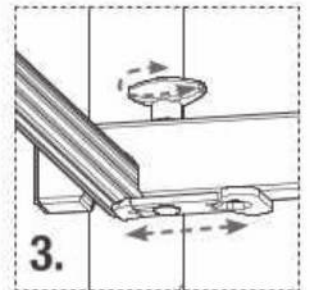
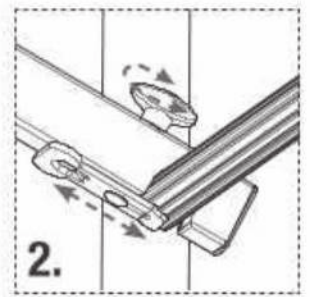
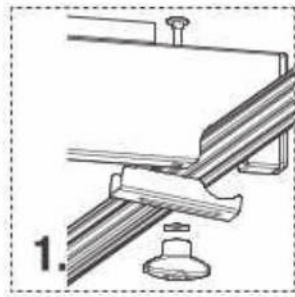
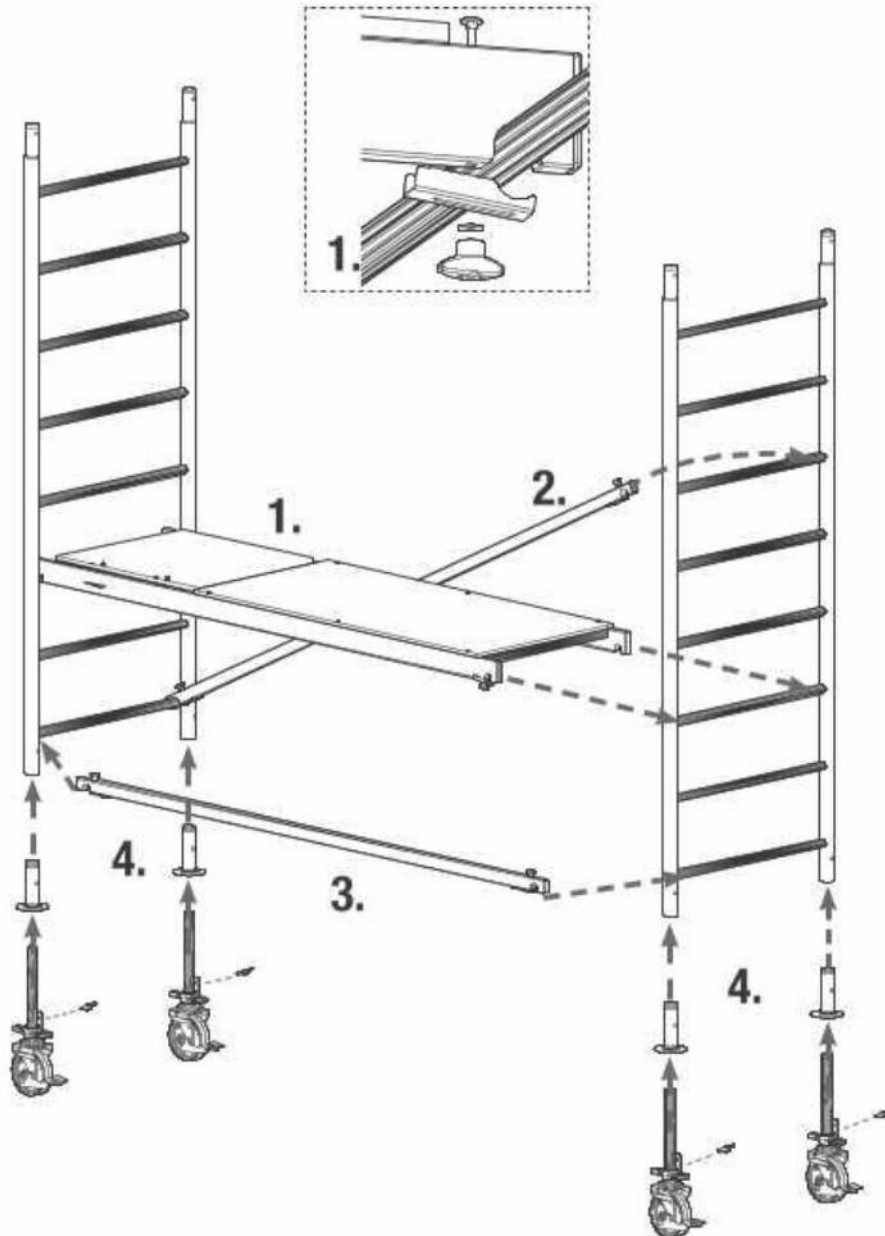

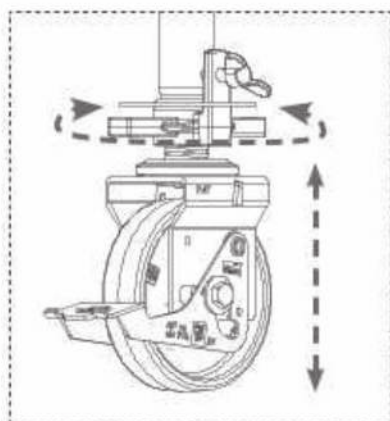
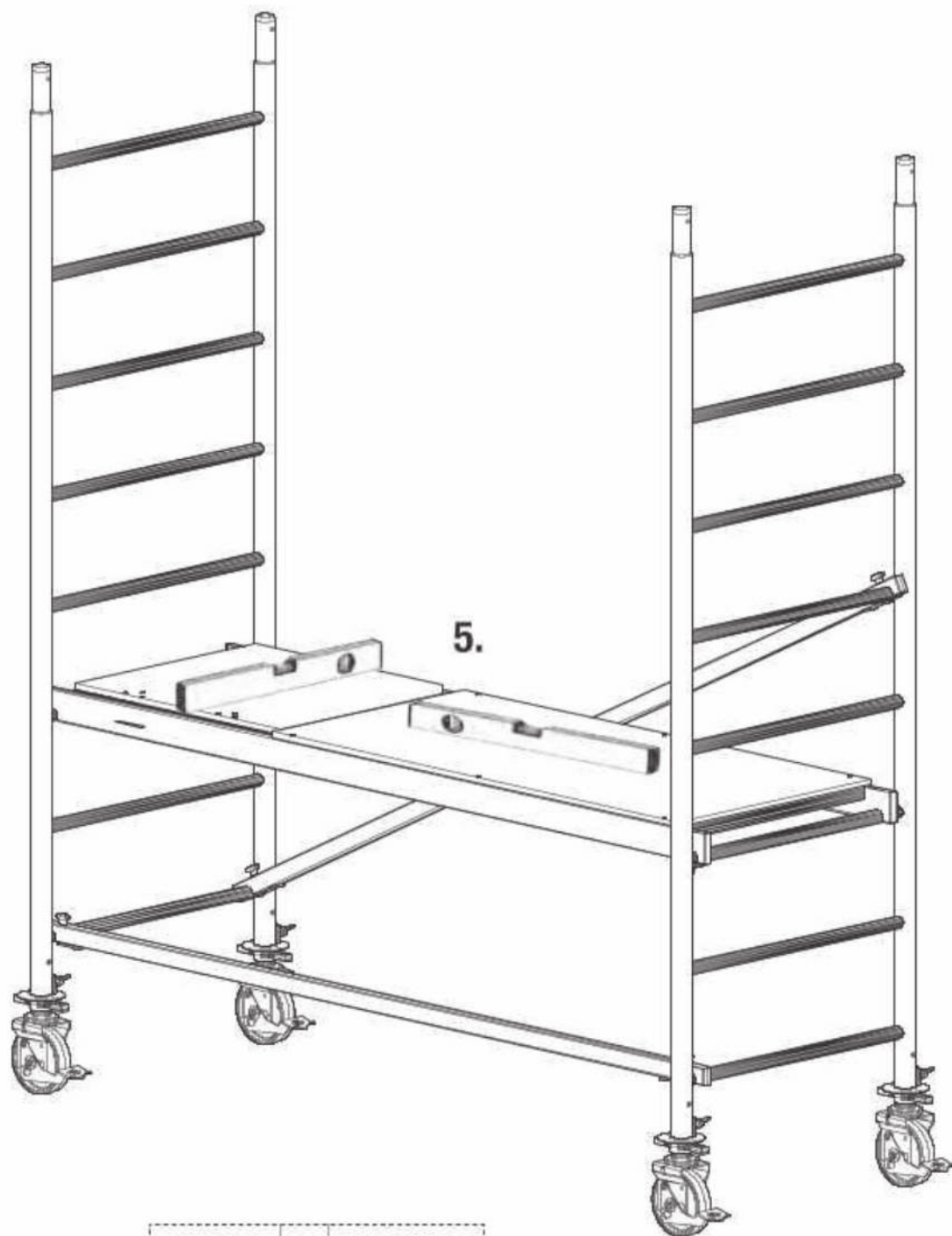

2a.

114 115

2x Art.-No. 912848

2x Art.-No. 914071

4x Art.-No. 914026

4x Art.-No. 914118

2b.

114 115

2x Art.-No. 912848

2x Art.-No. 914071

4x Art.-No. 914026

4x Art.-No. 914118

4b.

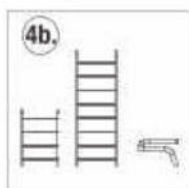

5,30 m; 7,30 m; 9,30 m; 11,30 m

	<p>1 x Art.-No. 915016</p>
	<p>2 x Art.-No. 915023</p>
	<p>6 x Art.-No. 704405</p>

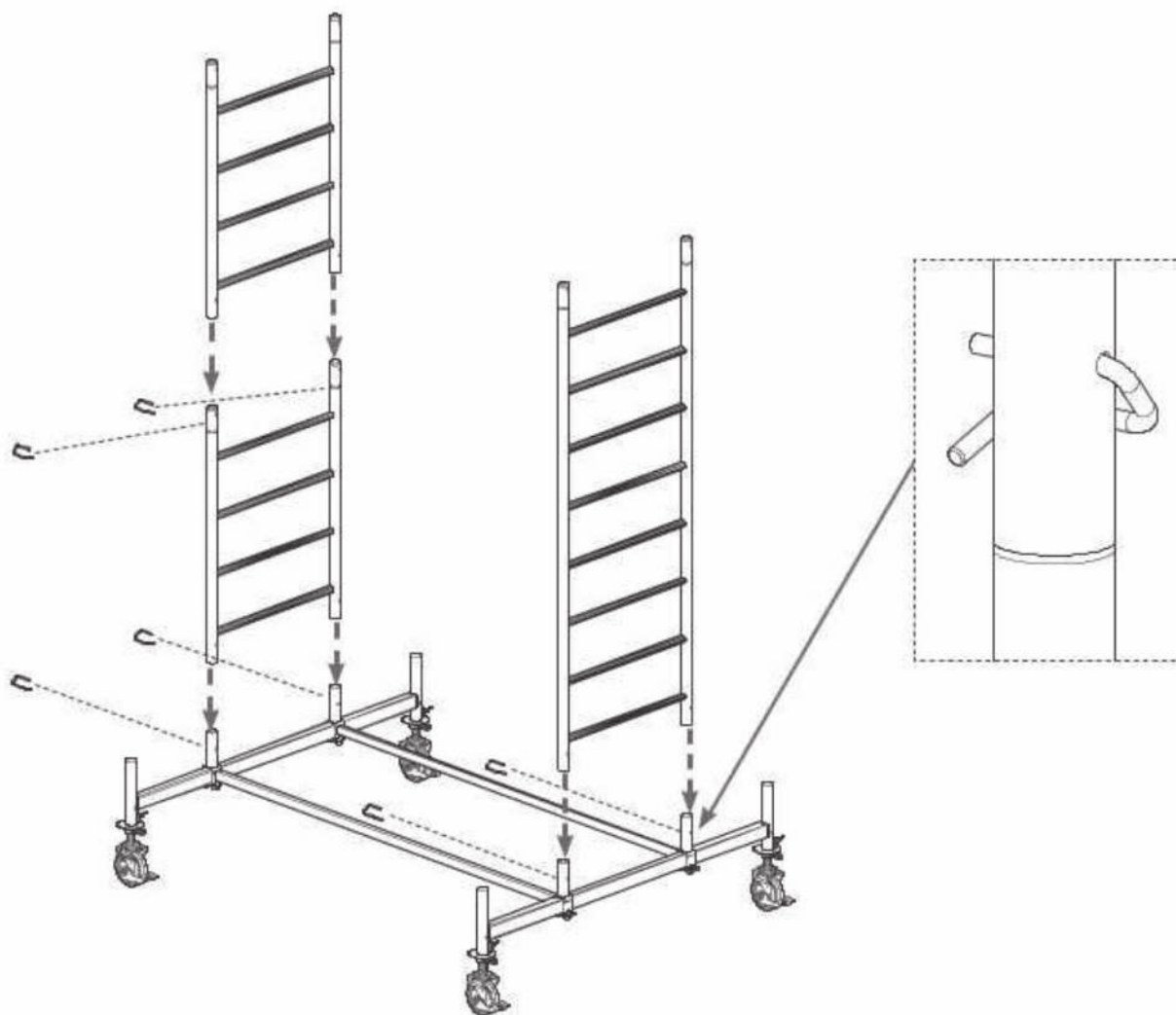

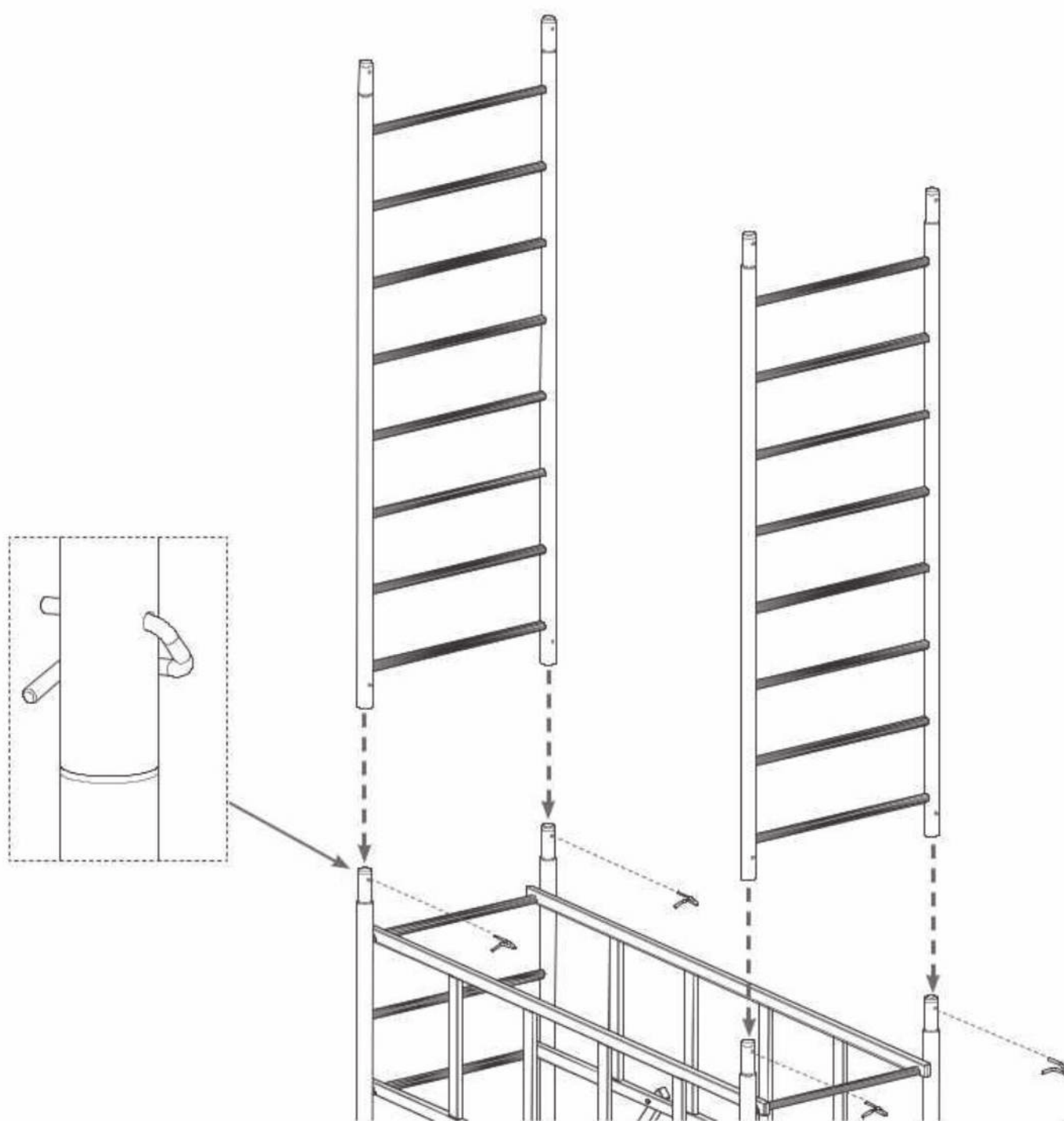
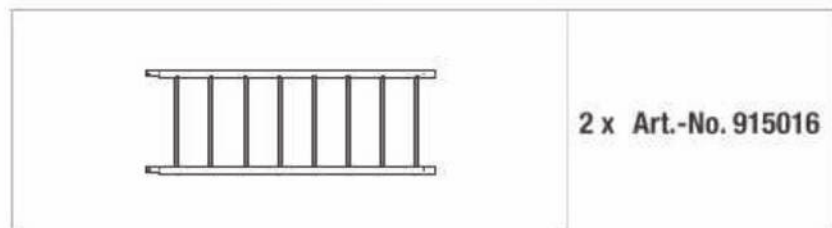
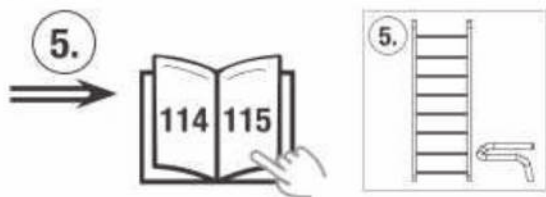

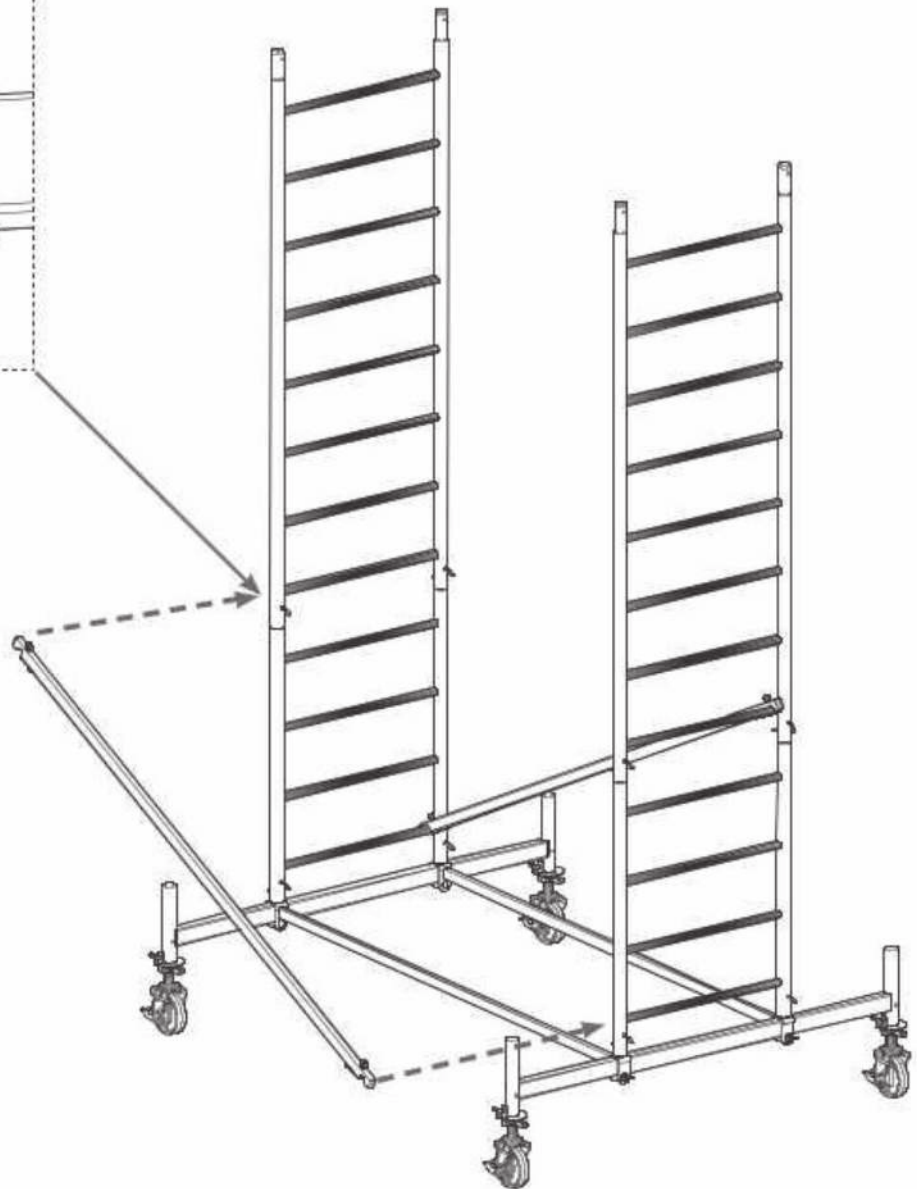
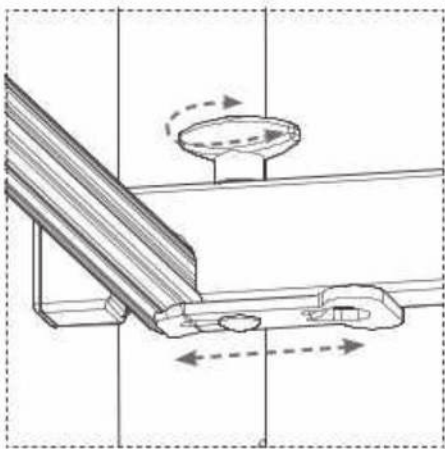
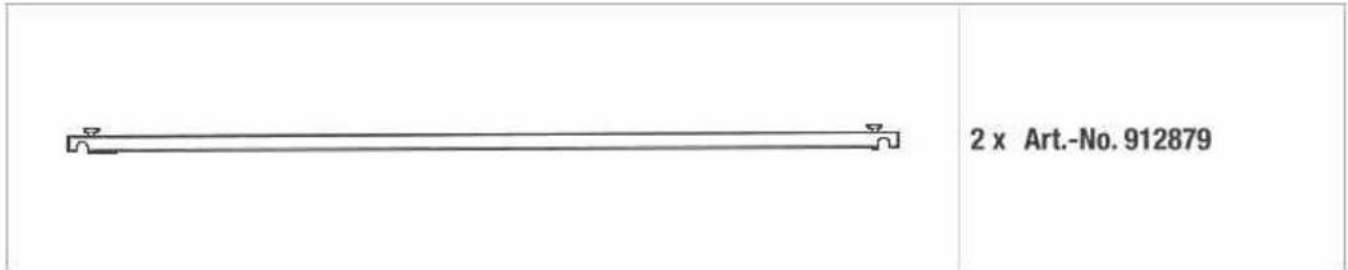
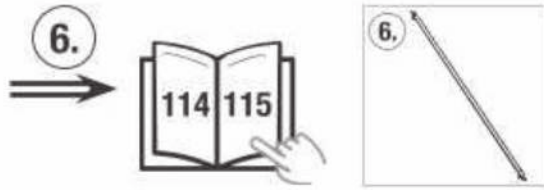

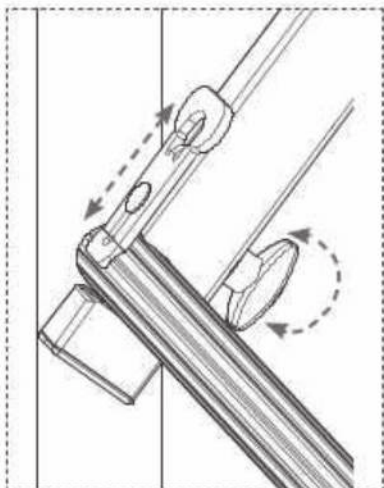
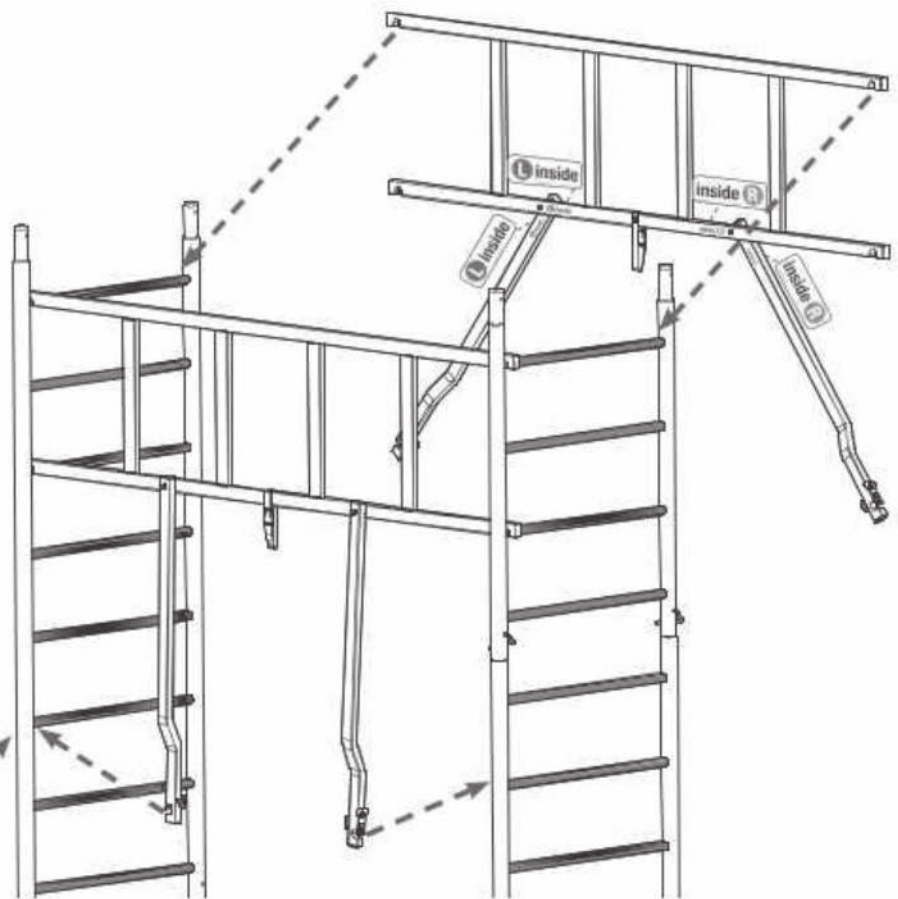
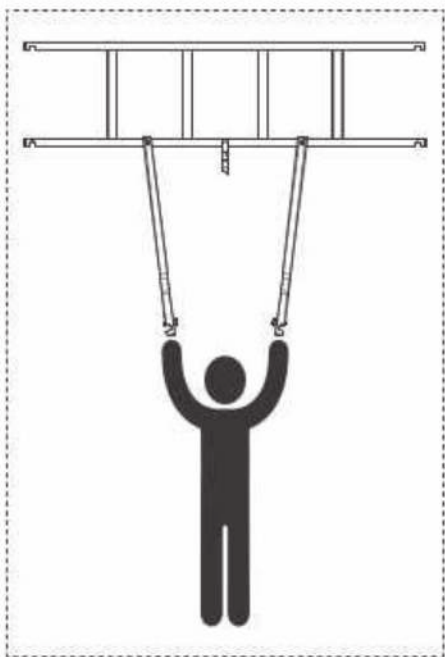
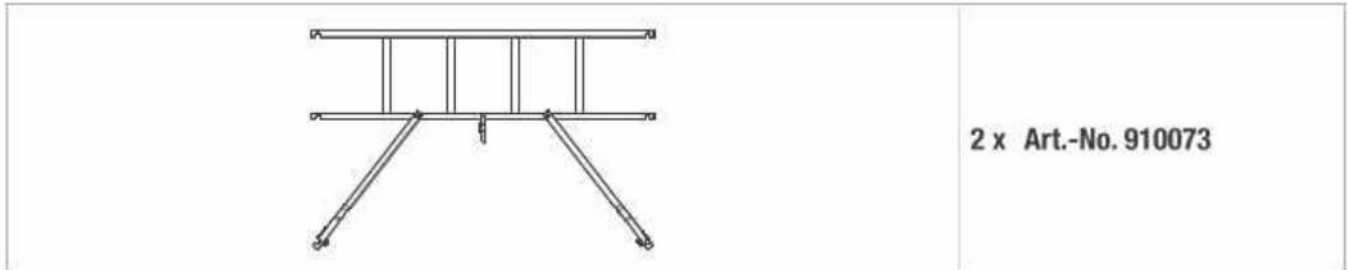
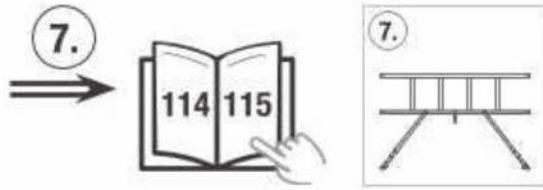

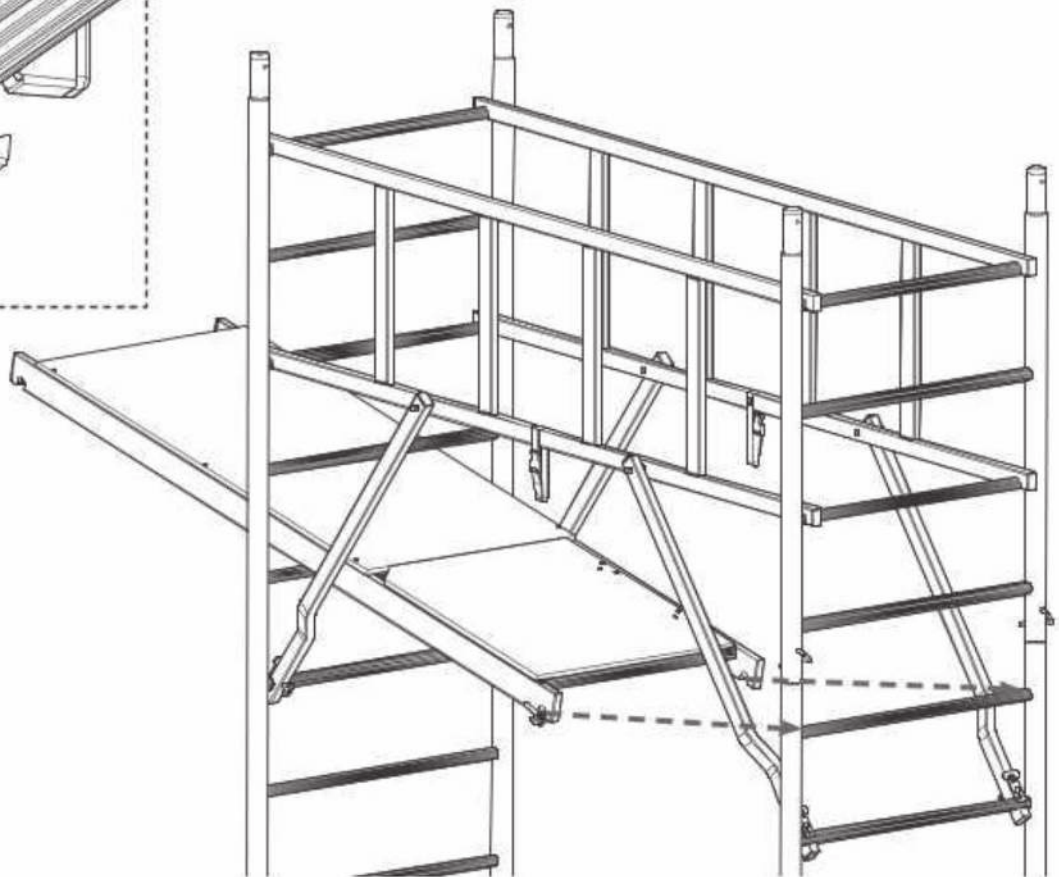
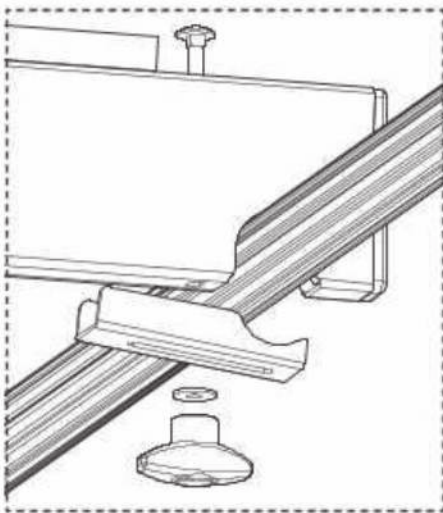
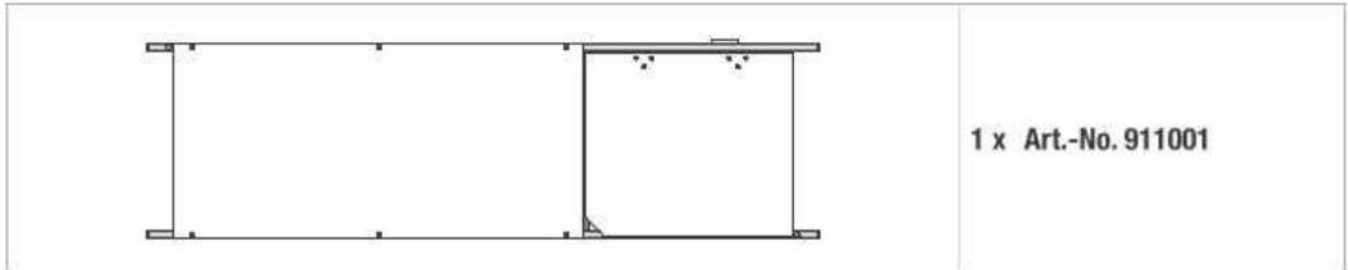
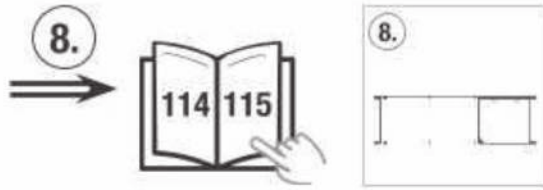

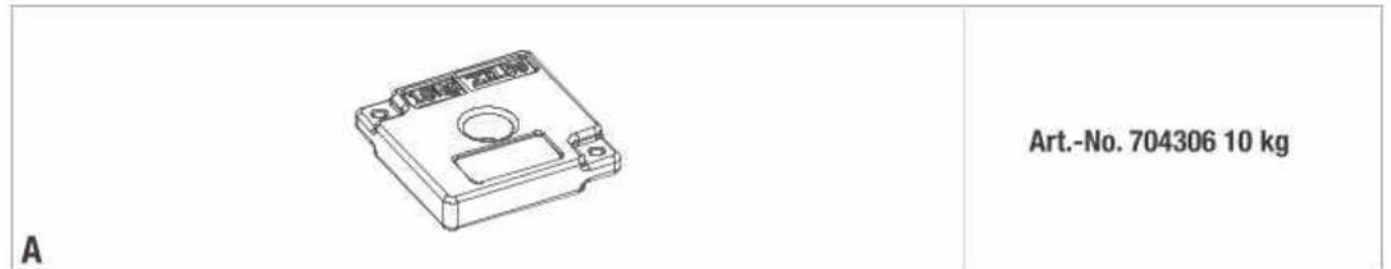
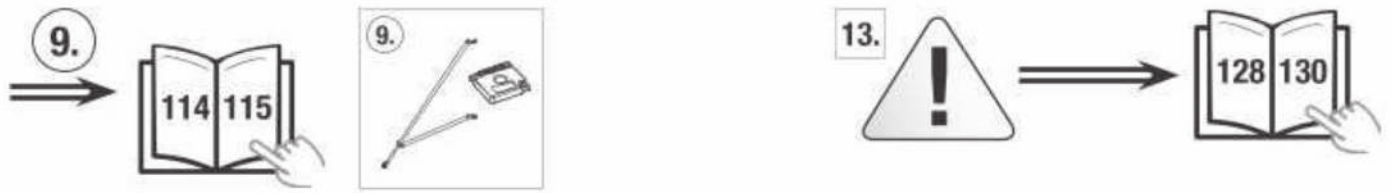

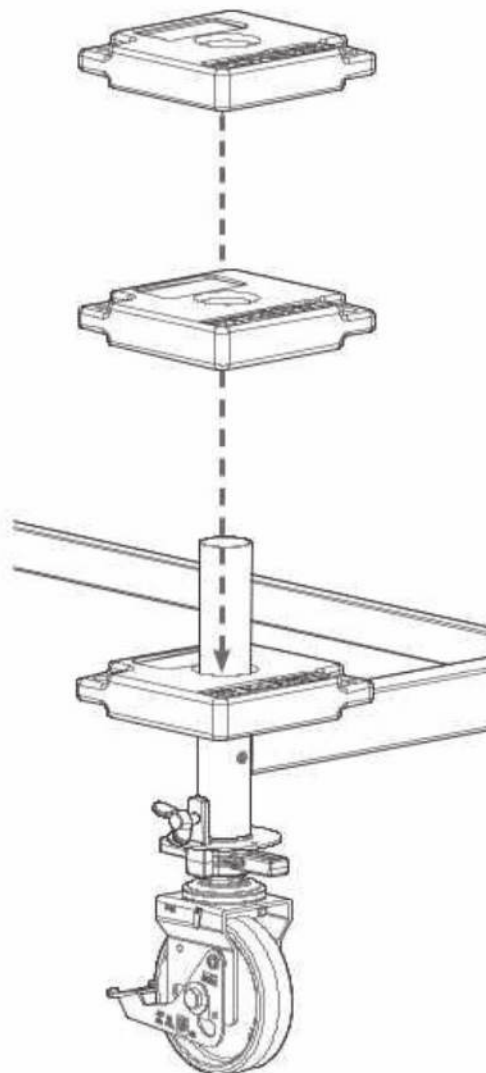

Art.-No. 704306 10 kg

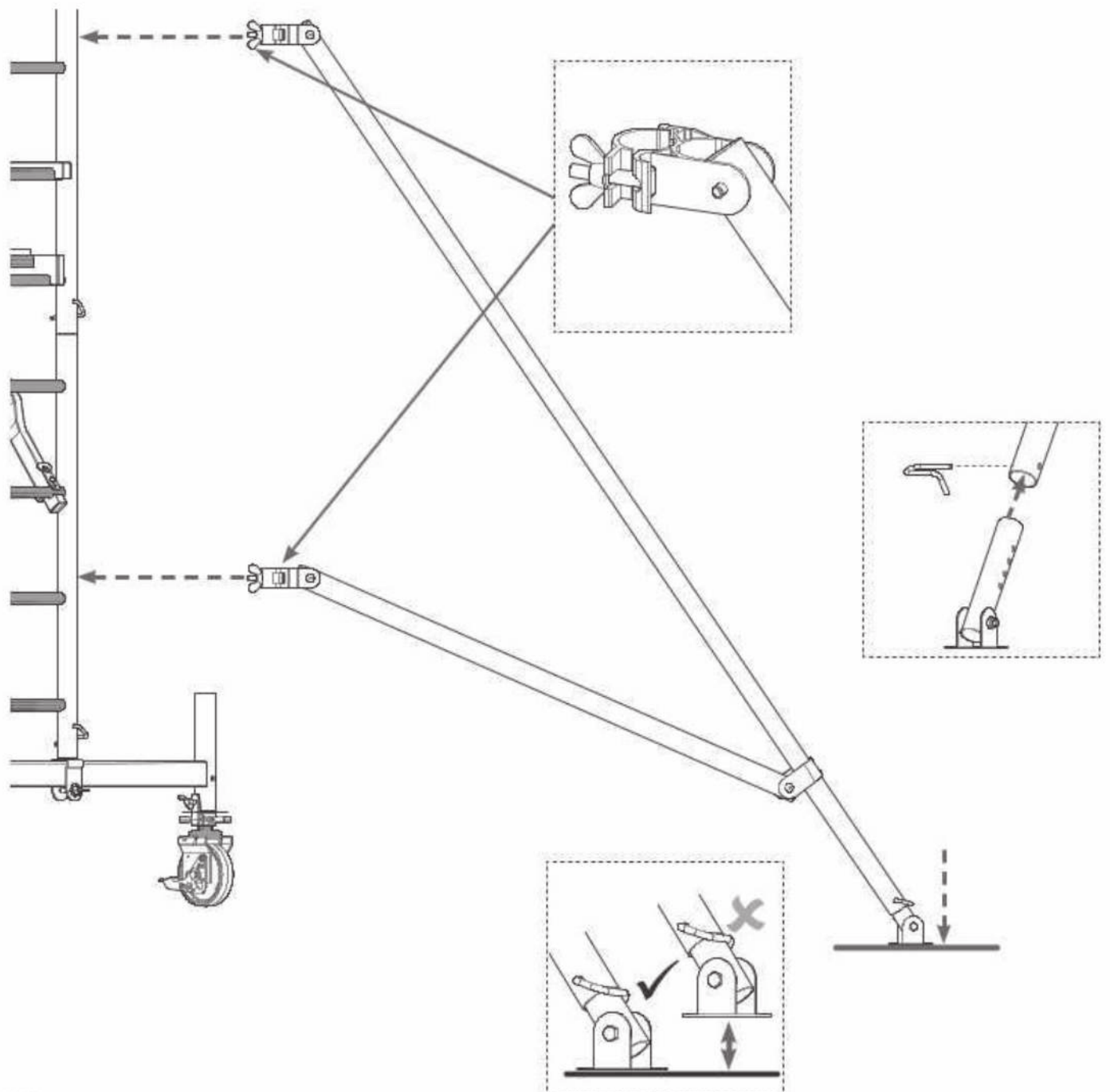
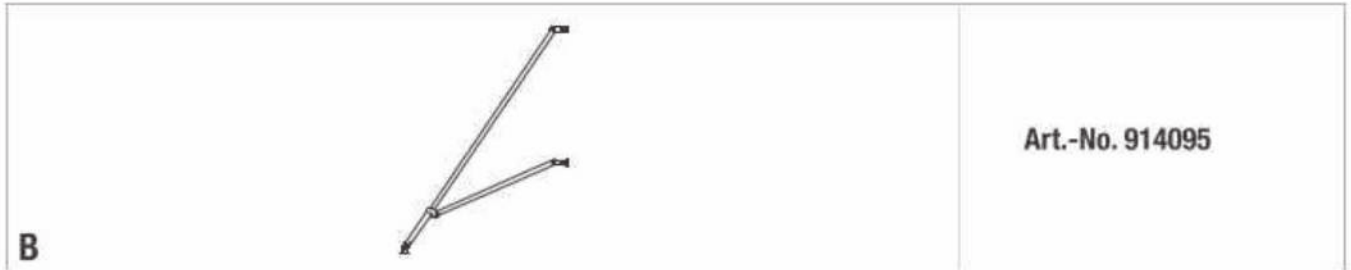
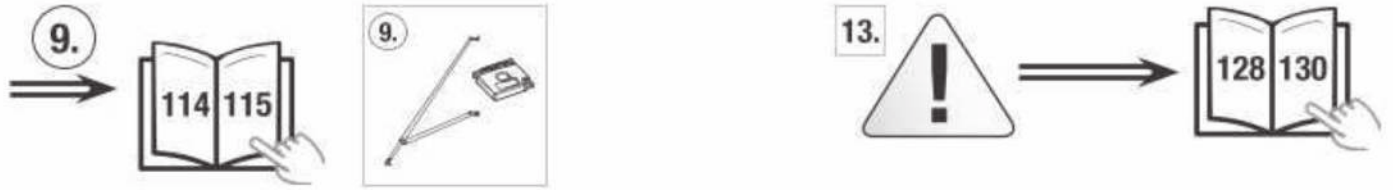

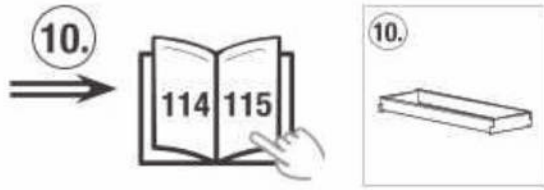



	<p>2 x Art.-No. 913517</p>
	<p>2 x Art.-No. 913555</p>

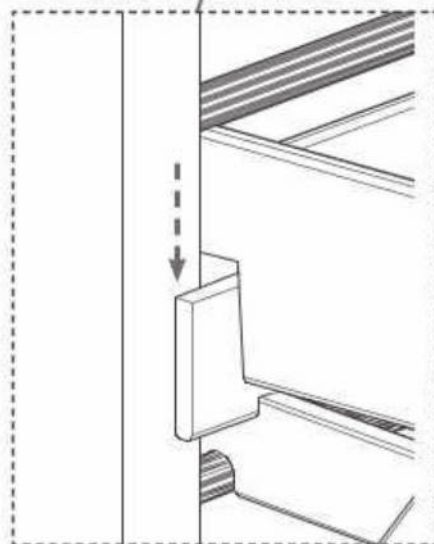
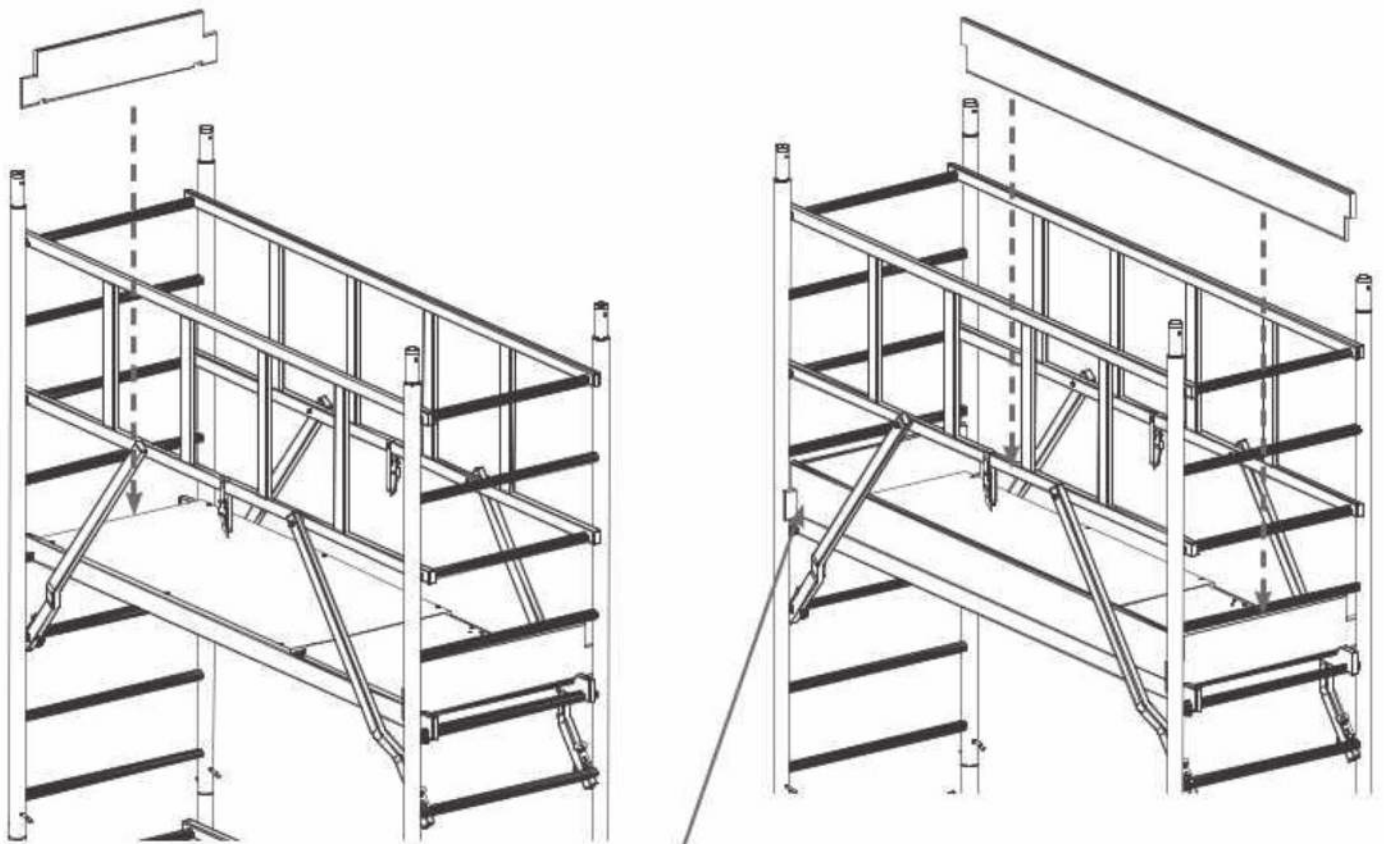

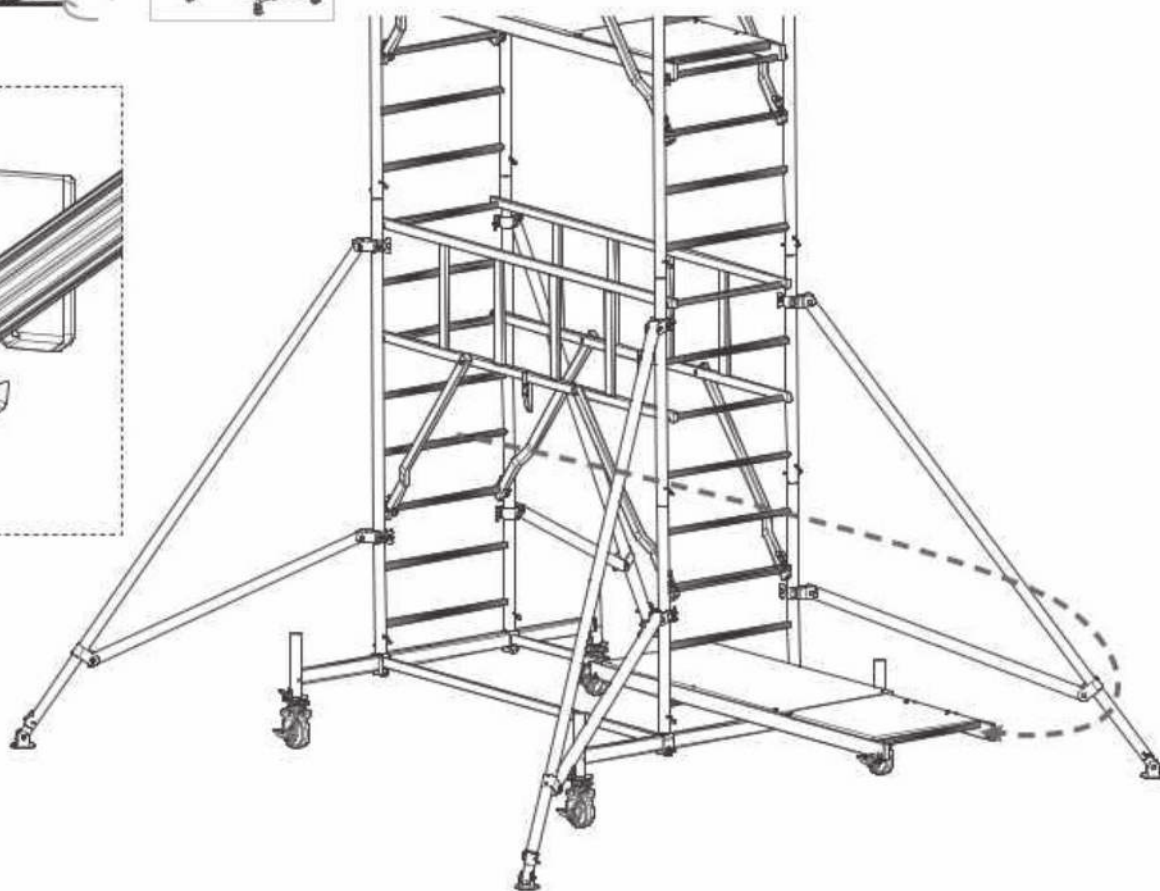
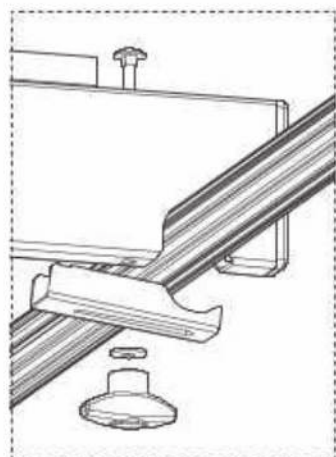
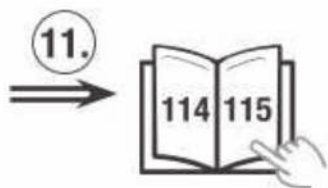



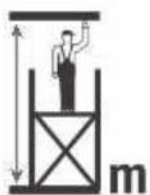

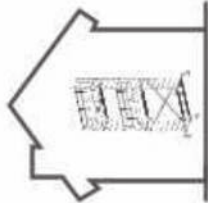

13.

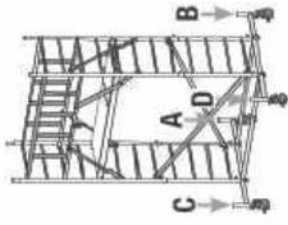
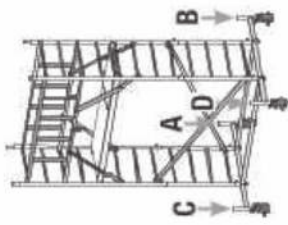
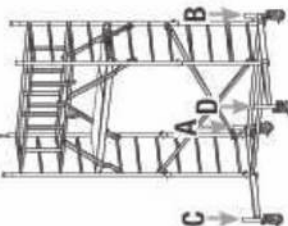
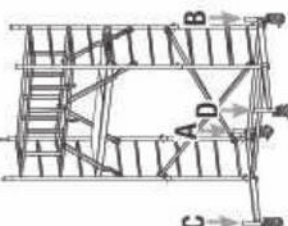
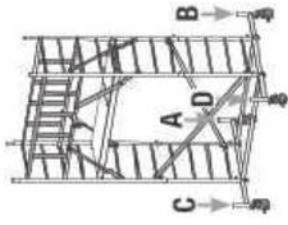
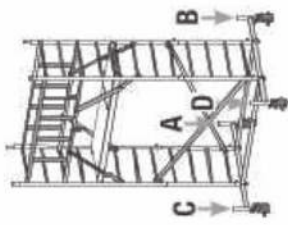
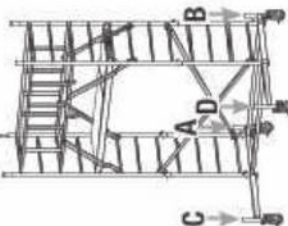
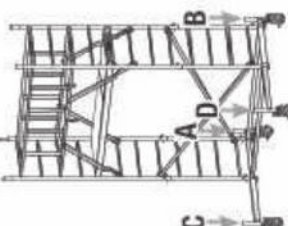
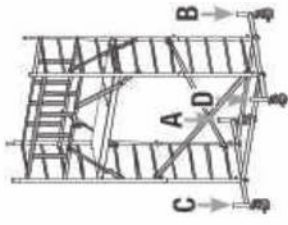
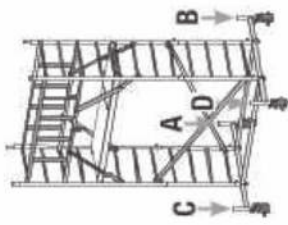
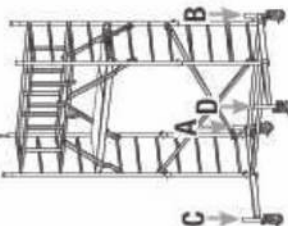
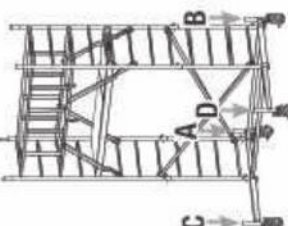
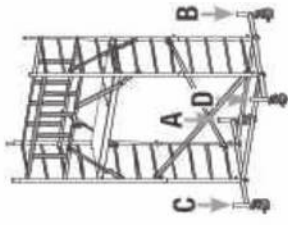
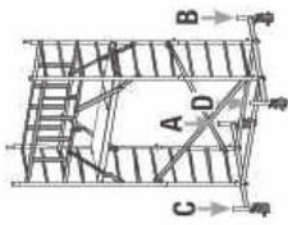
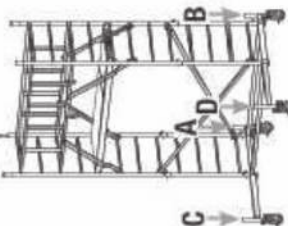
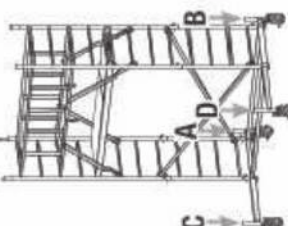
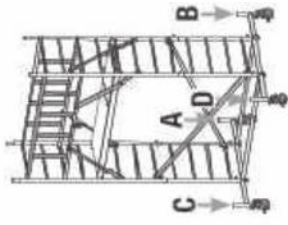
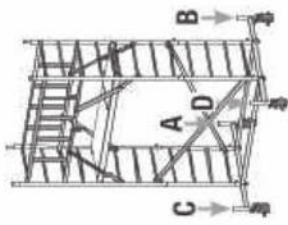
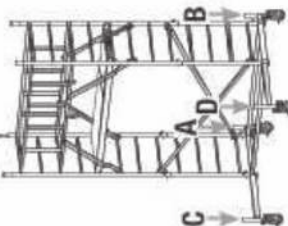
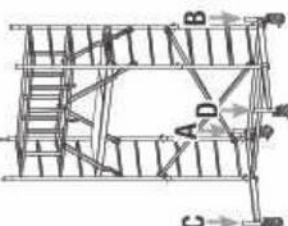
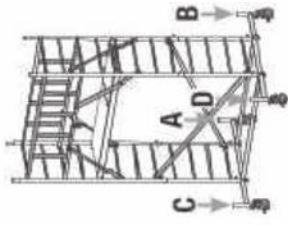
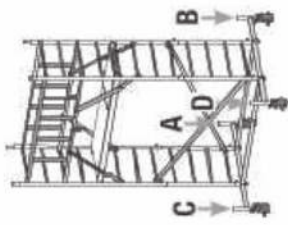
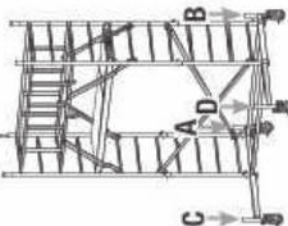
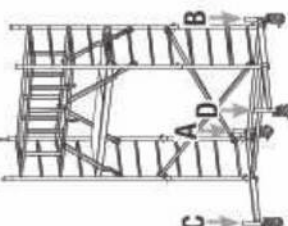
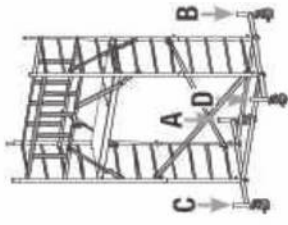
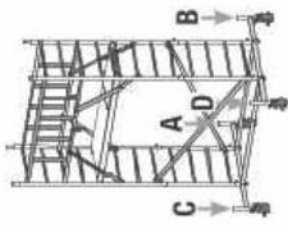
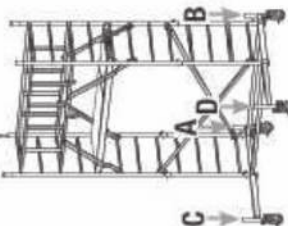
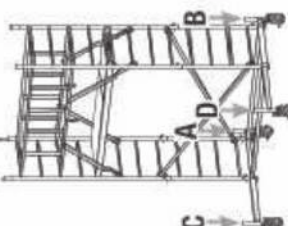
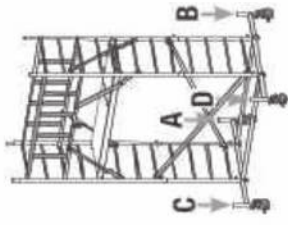
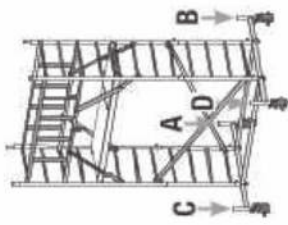
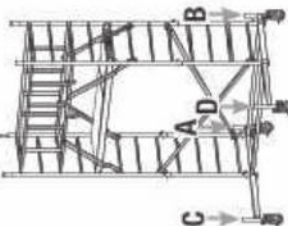
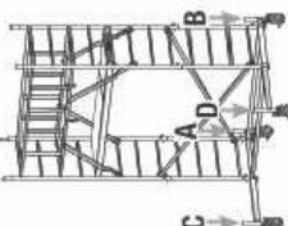
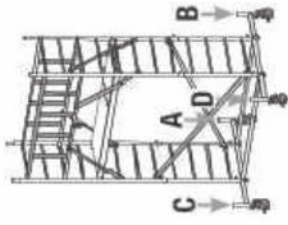
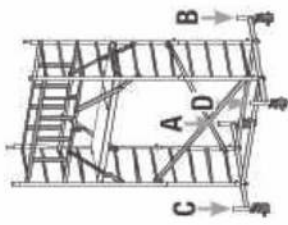
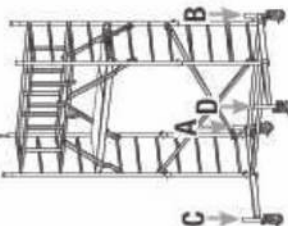
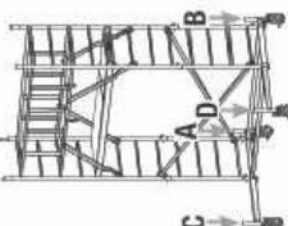
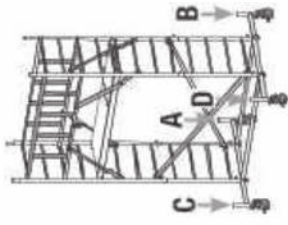
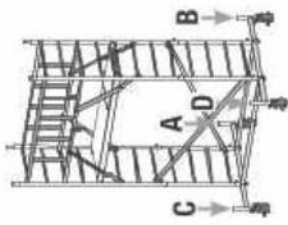
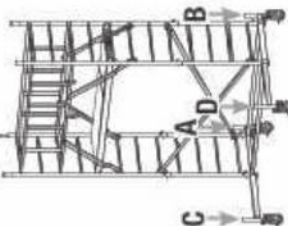
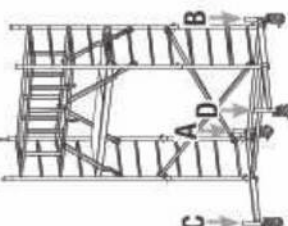
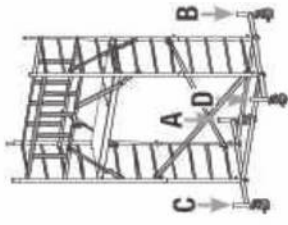
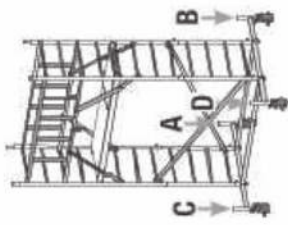
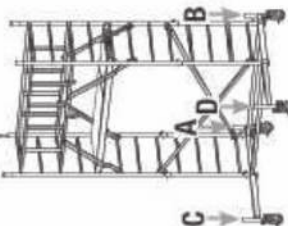
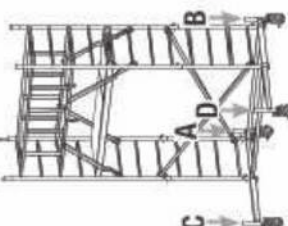
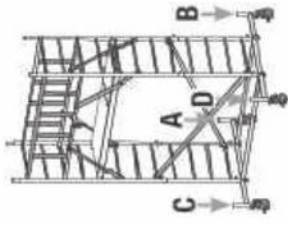
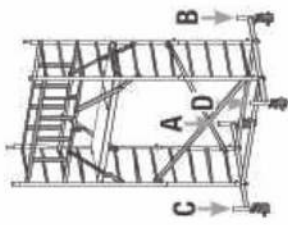
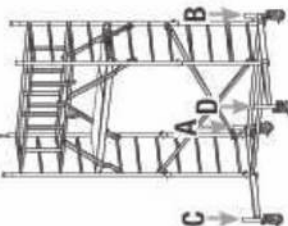
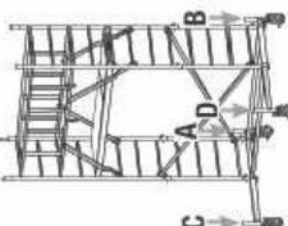
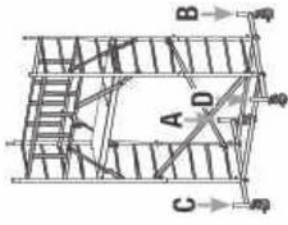
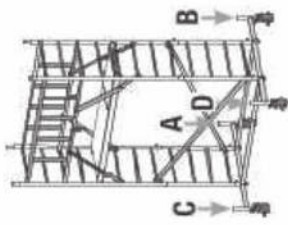
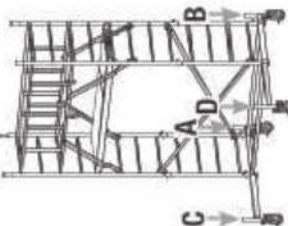
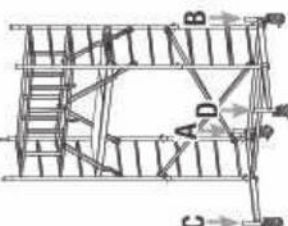
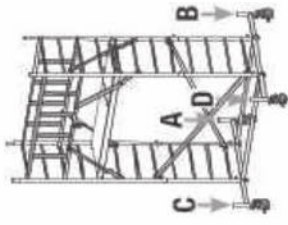
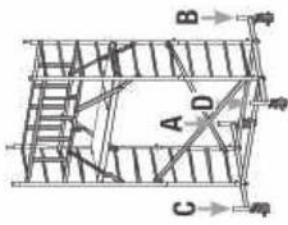
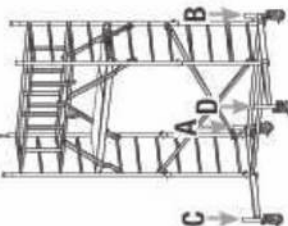
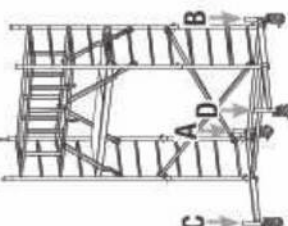
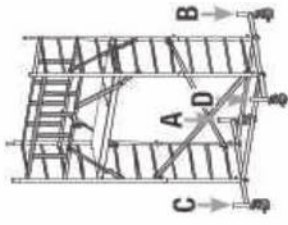
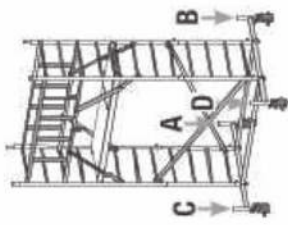
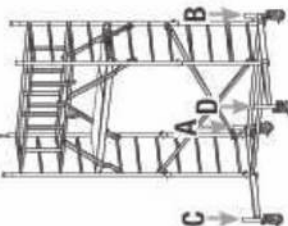
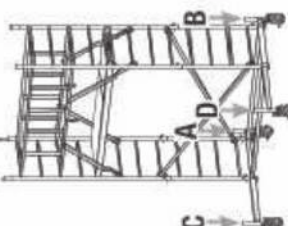
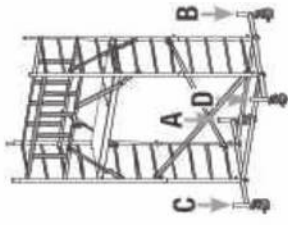
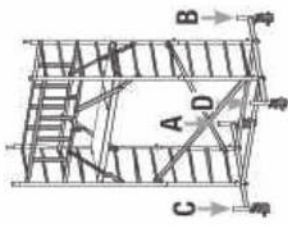
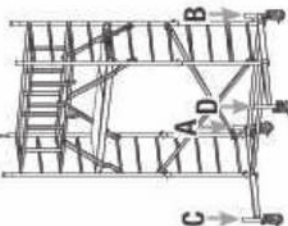
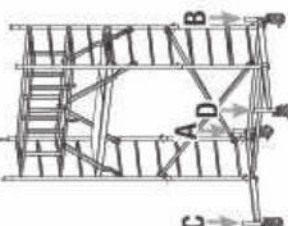
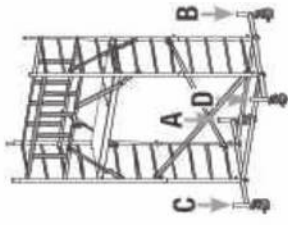
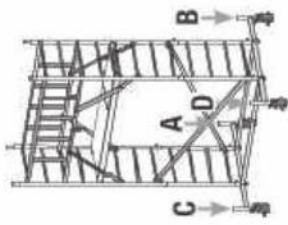
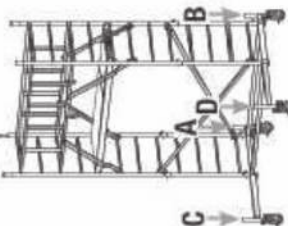
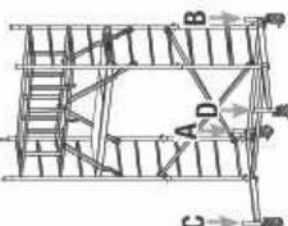
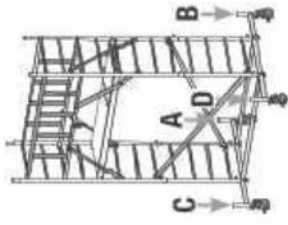
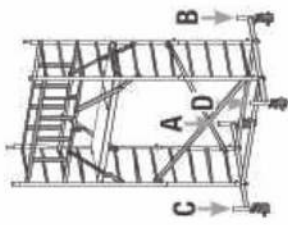
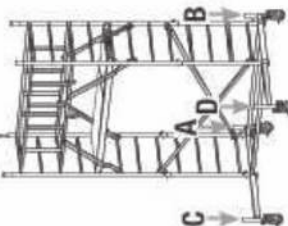
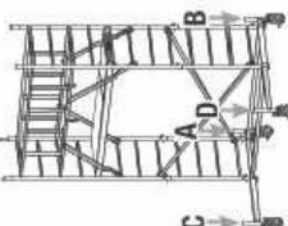
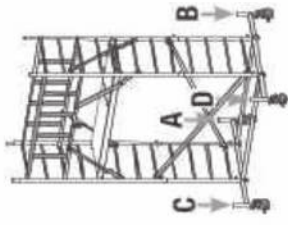
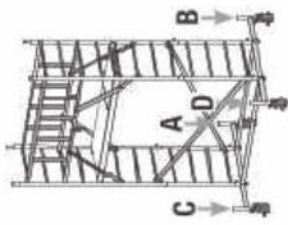
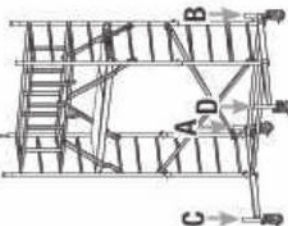
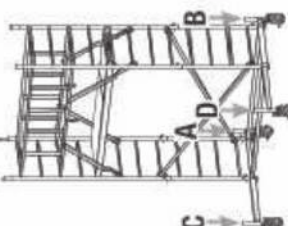
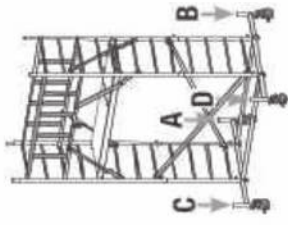
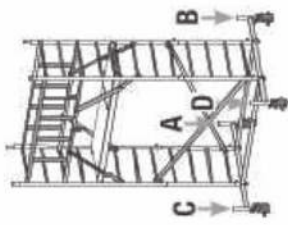
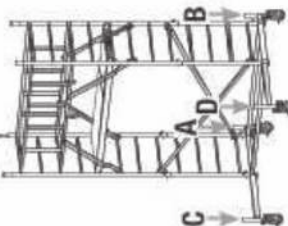
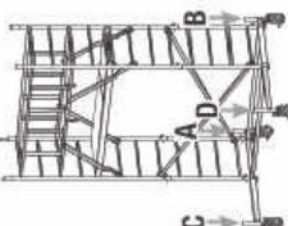
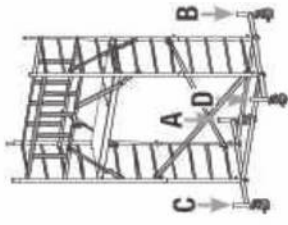
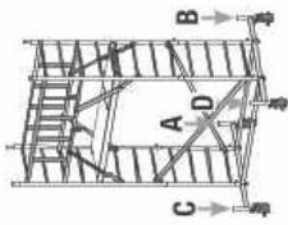
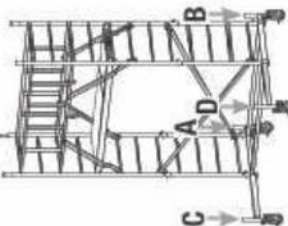
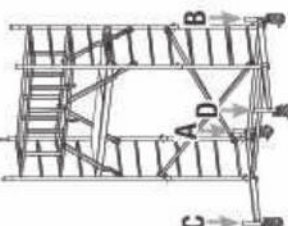
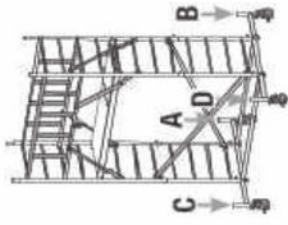
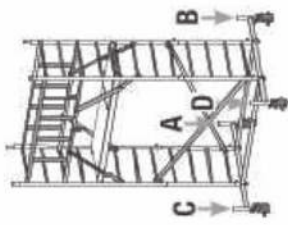
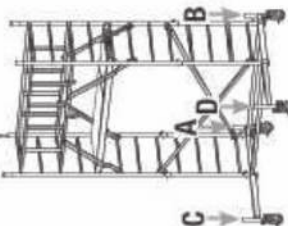
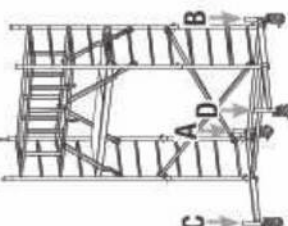
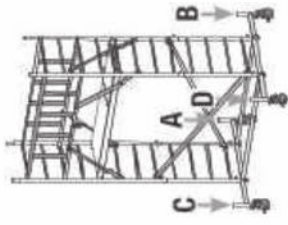
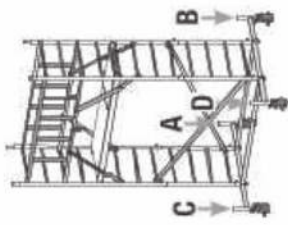
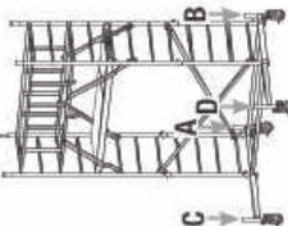
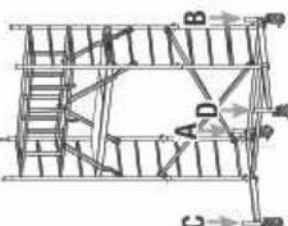
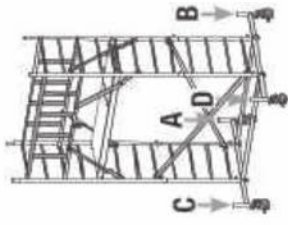
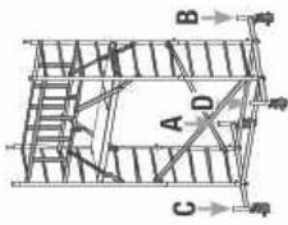
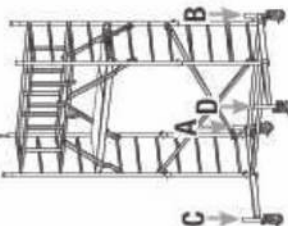
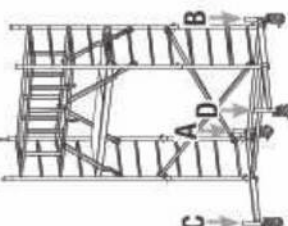
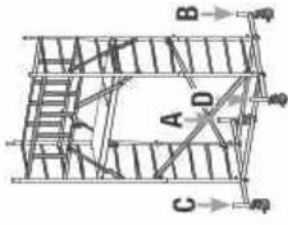
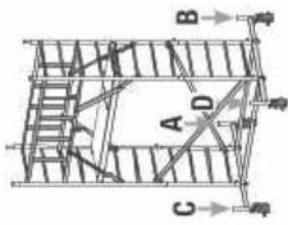
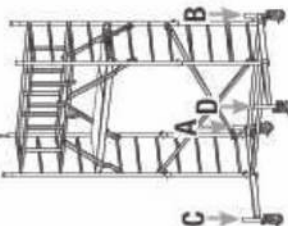
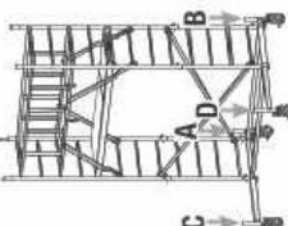
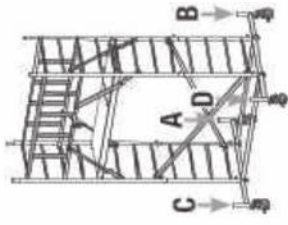
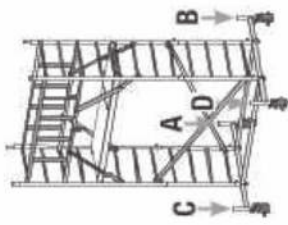
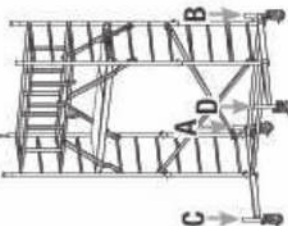
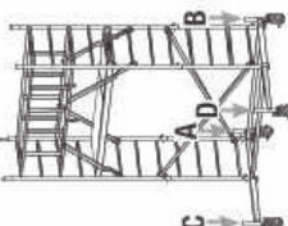
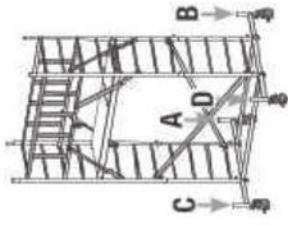
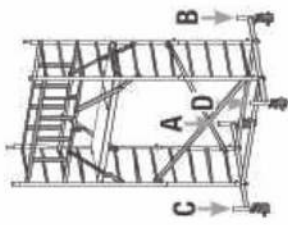
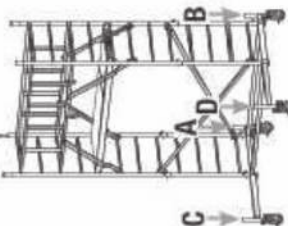
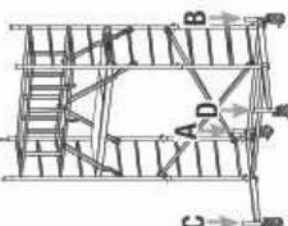
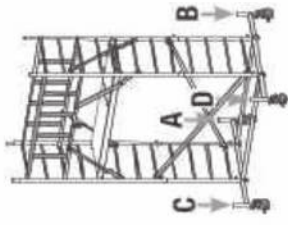
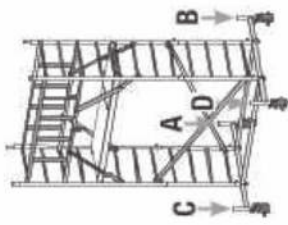
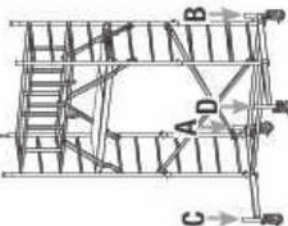
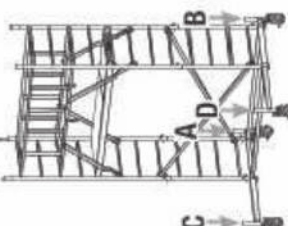
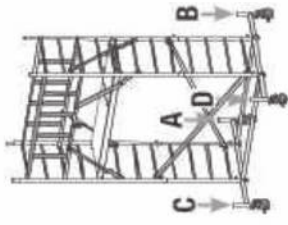
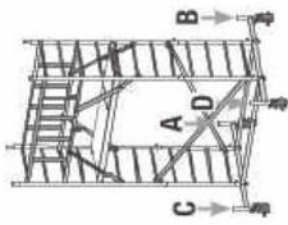
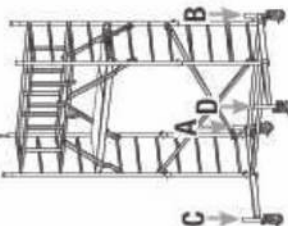
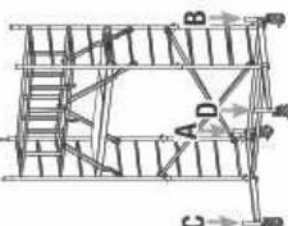
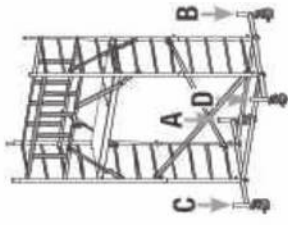
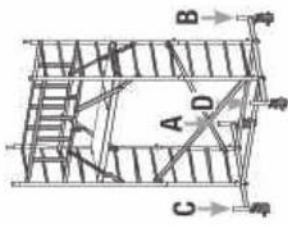
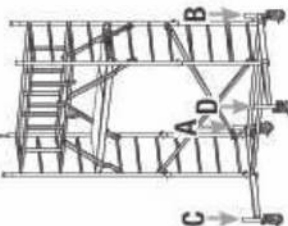
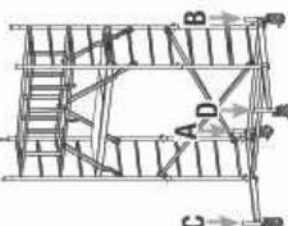
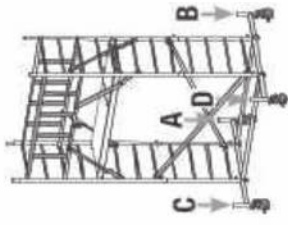
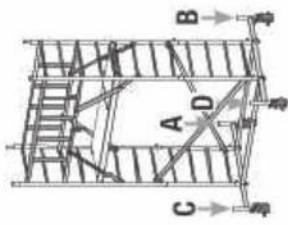
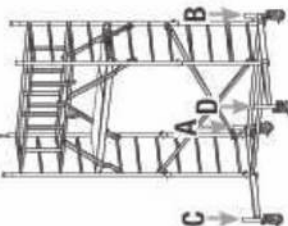
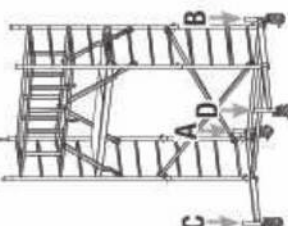
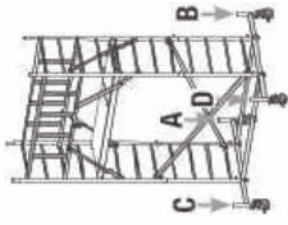
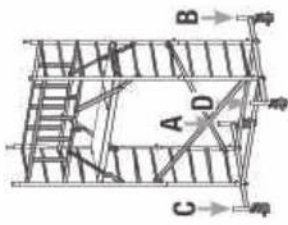
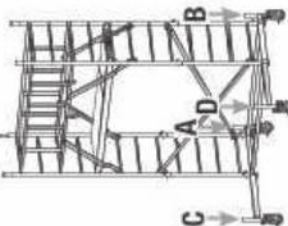
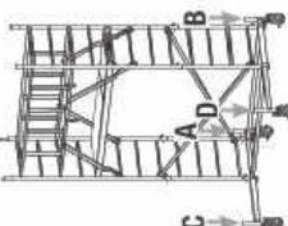
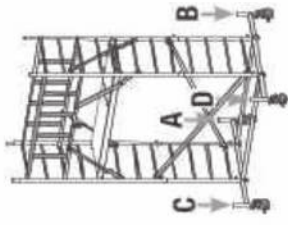
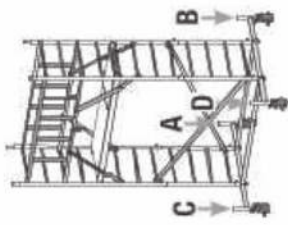
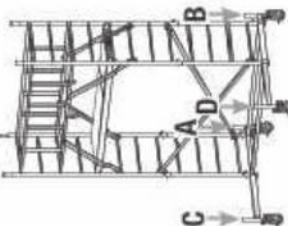
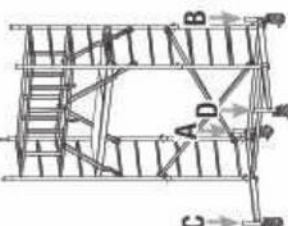
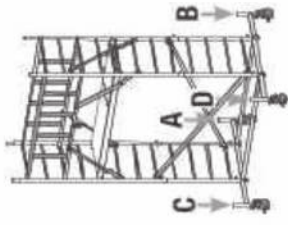
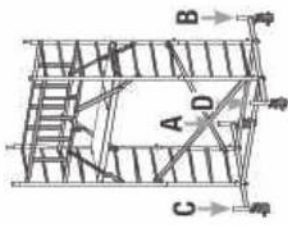
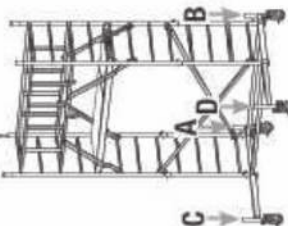
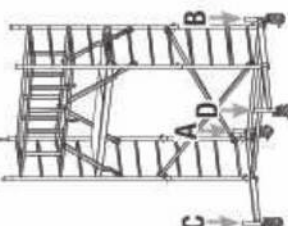
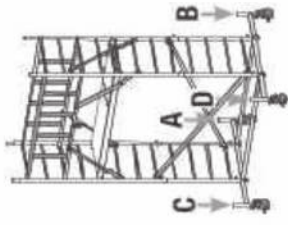
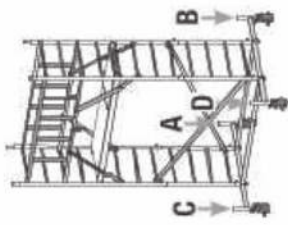
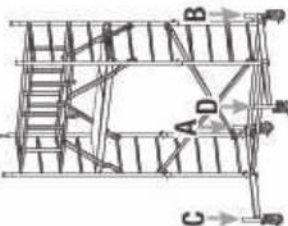
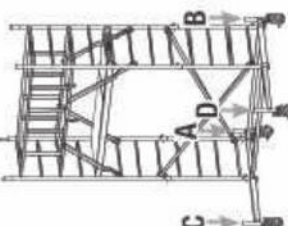
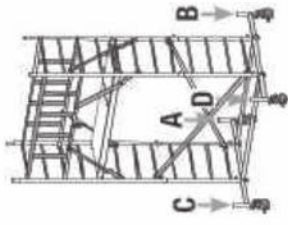
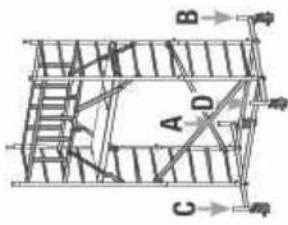
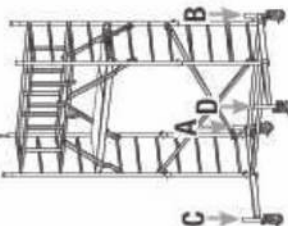
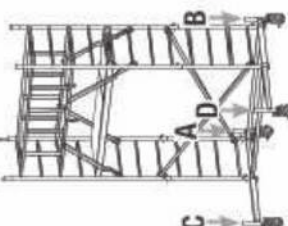
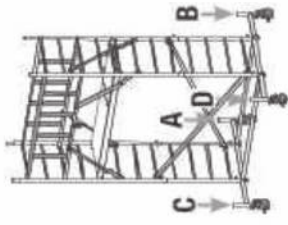
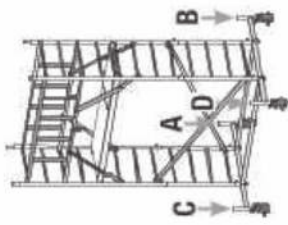
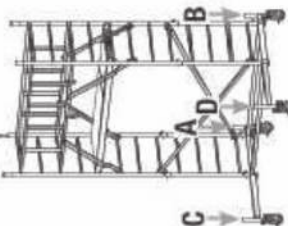
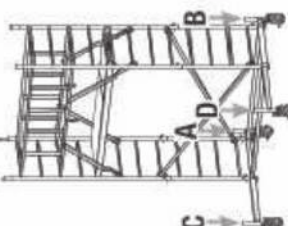
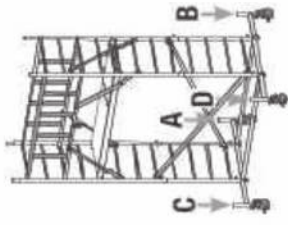
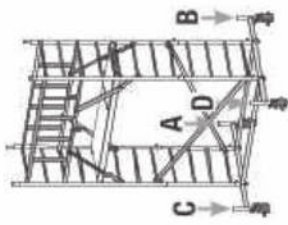
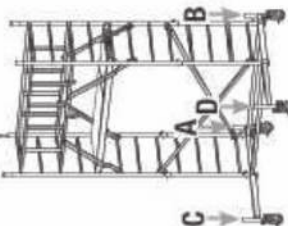
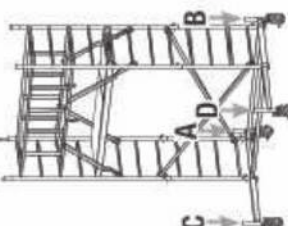
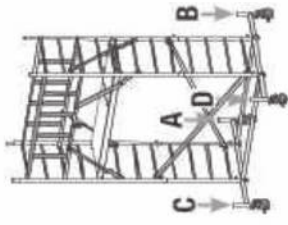
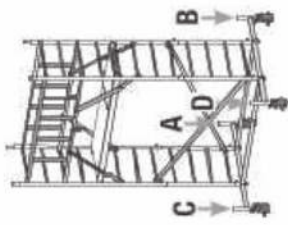
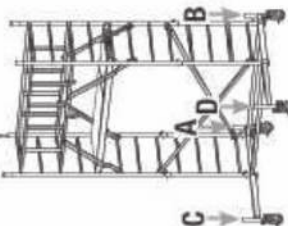
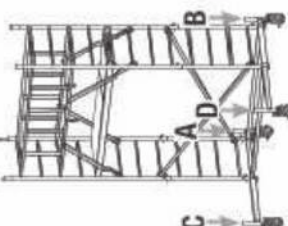
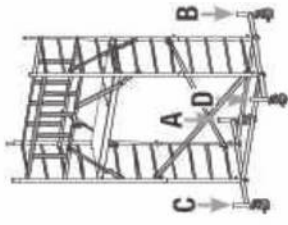
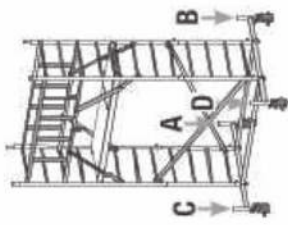
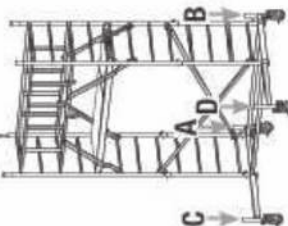
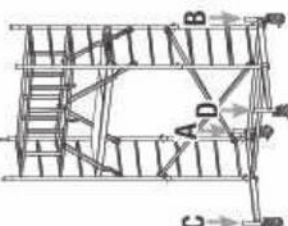
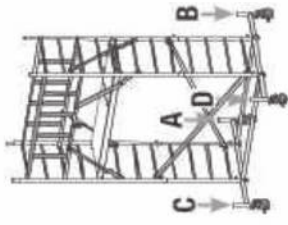
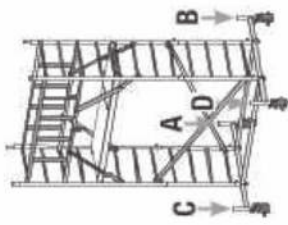
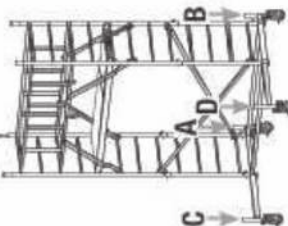
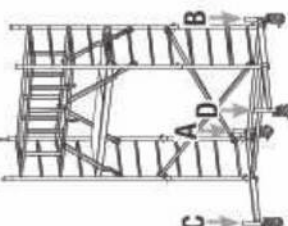
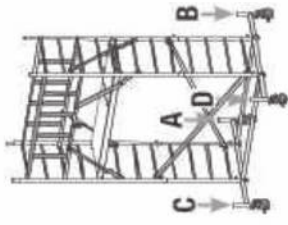
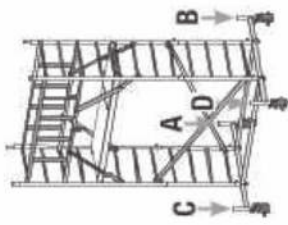
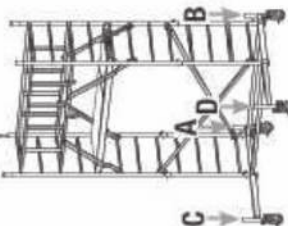
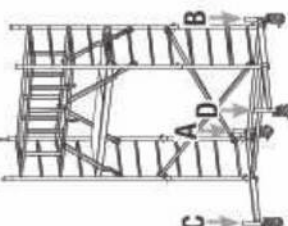
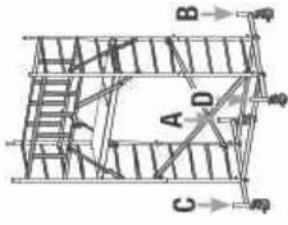
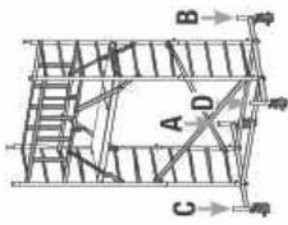
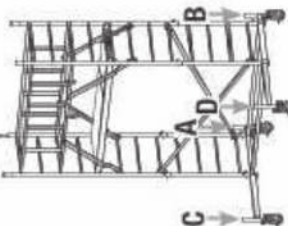
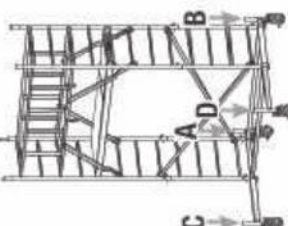
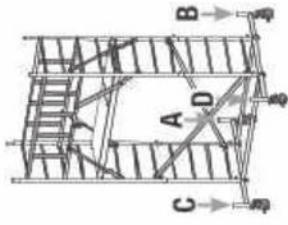
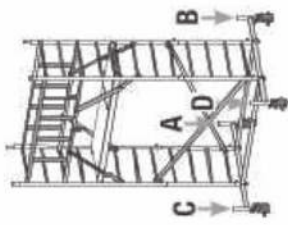
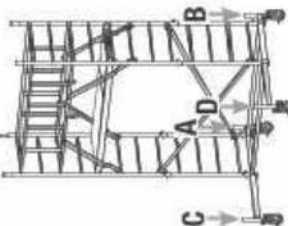
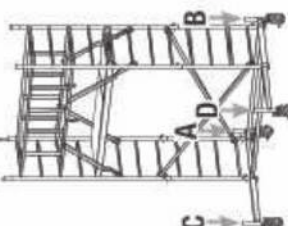
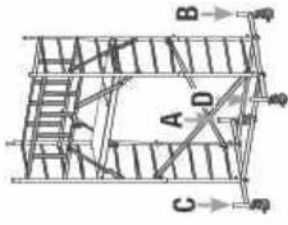
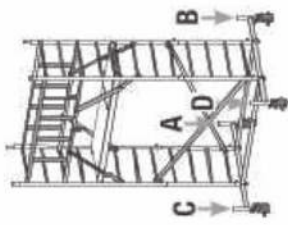
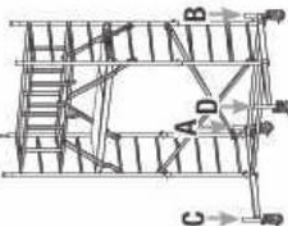
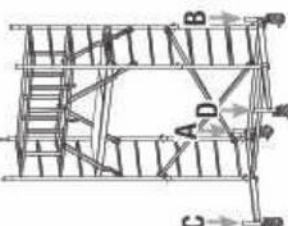
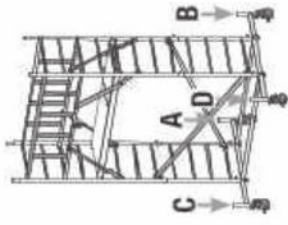
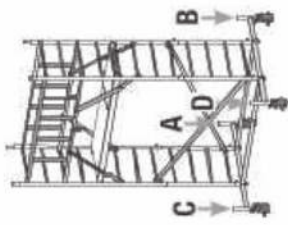
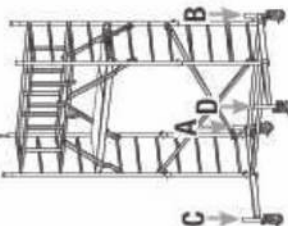
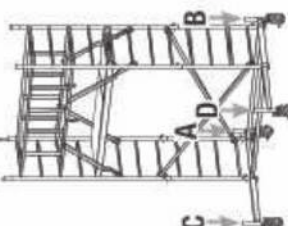
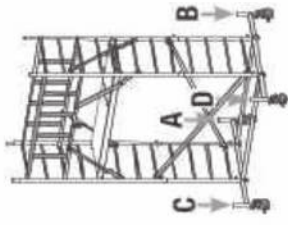
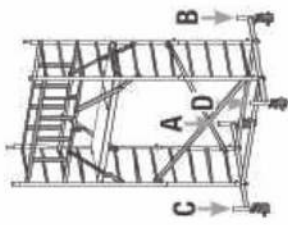
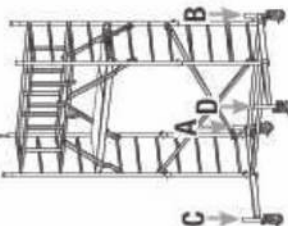
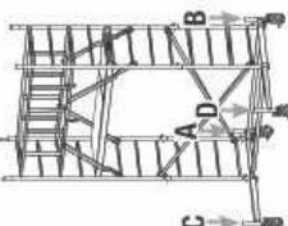
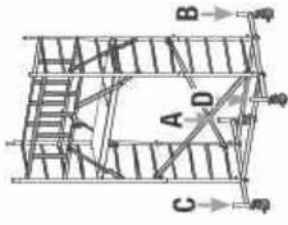
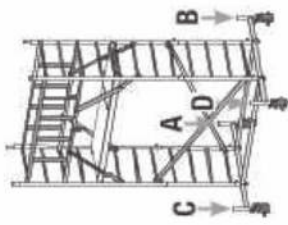
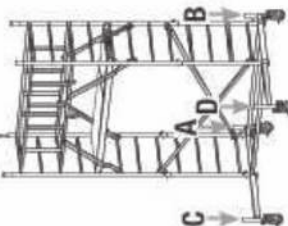
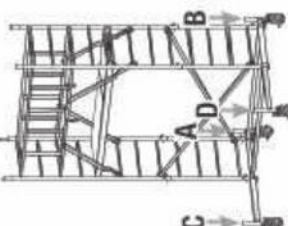
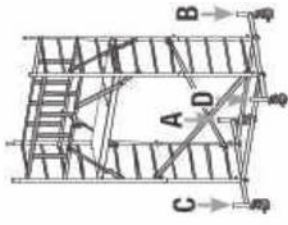
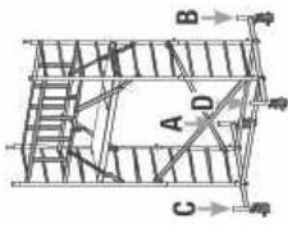
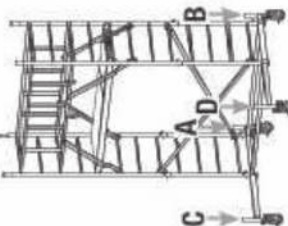
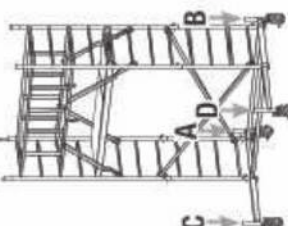
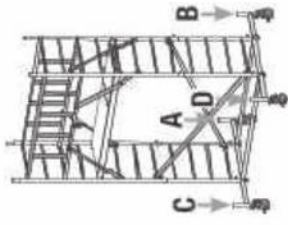
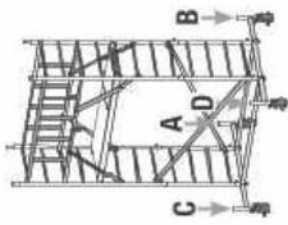
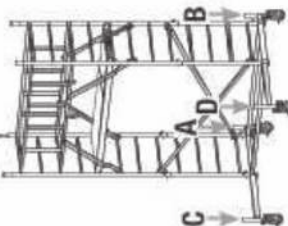
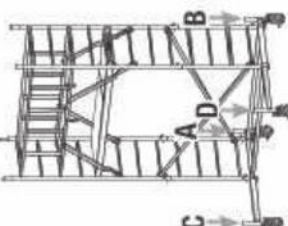
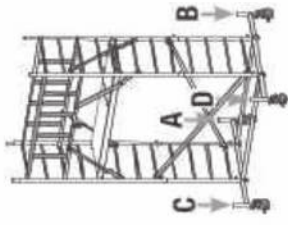
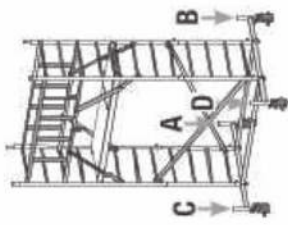
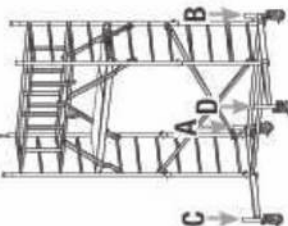
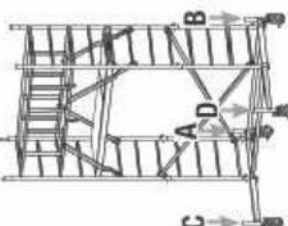
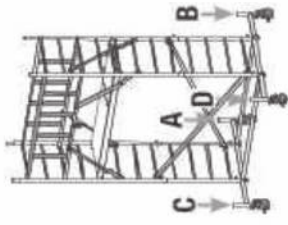
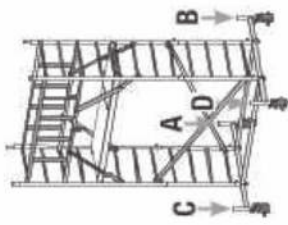
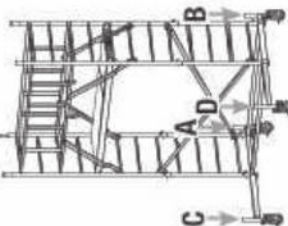
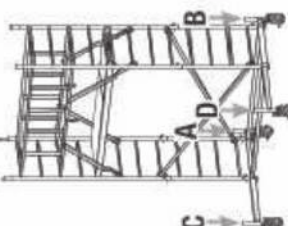
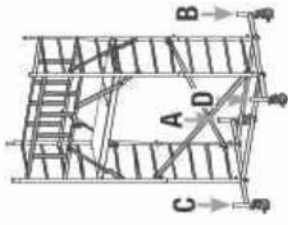
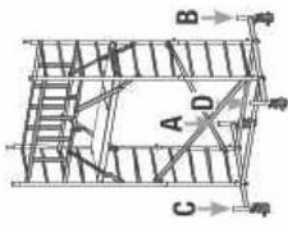
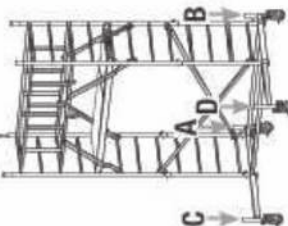
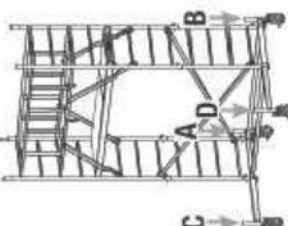
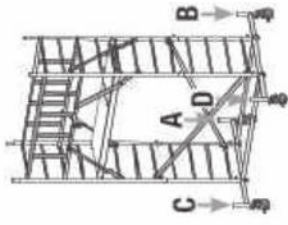
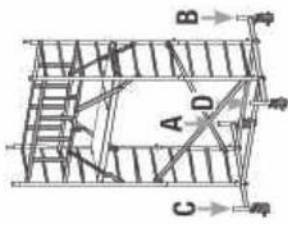
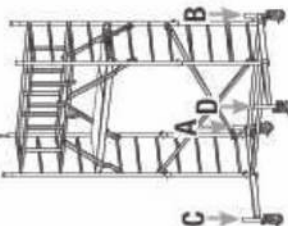
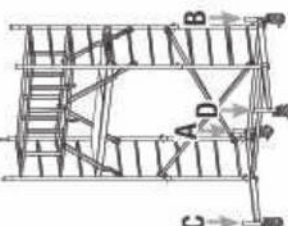
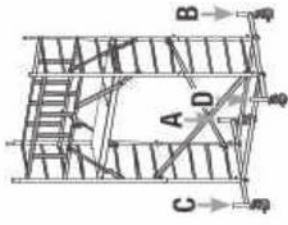
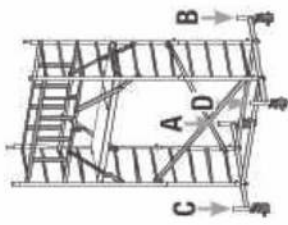
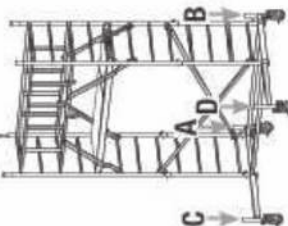
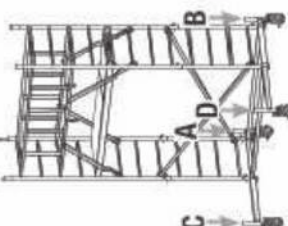
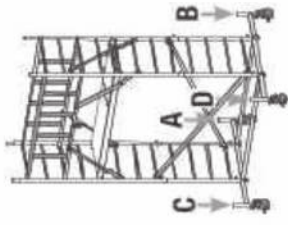
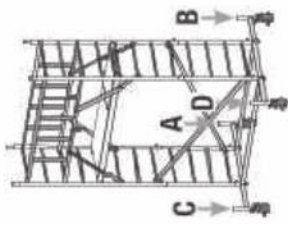
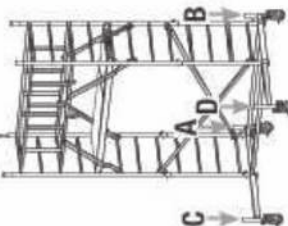
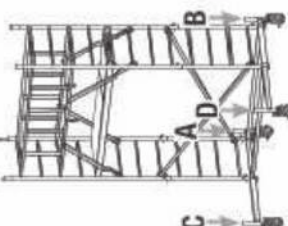
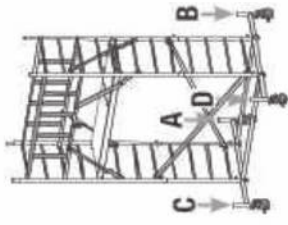
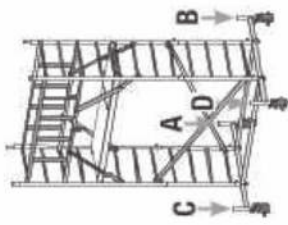
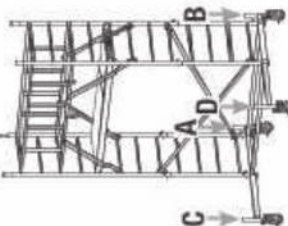
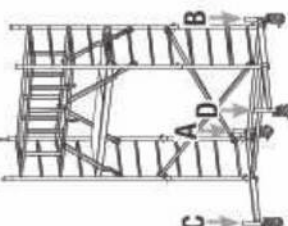
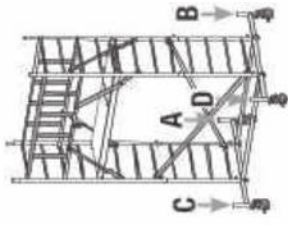
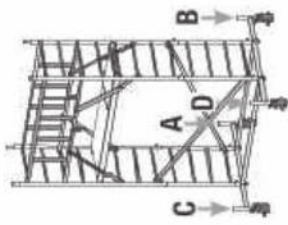
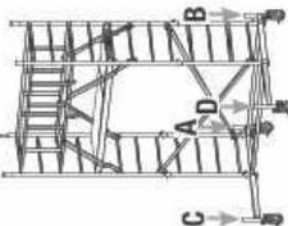
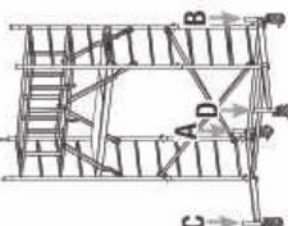
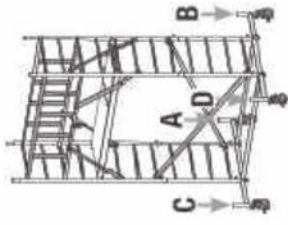
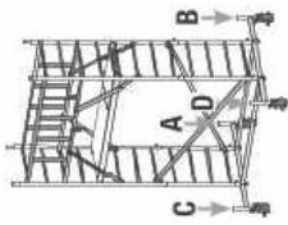
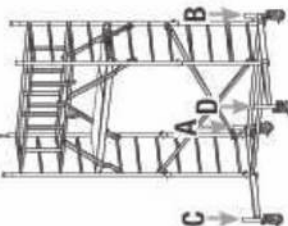
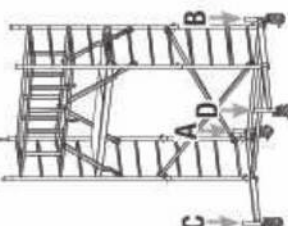
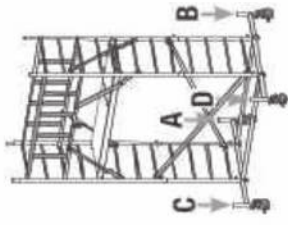
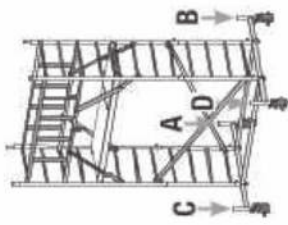
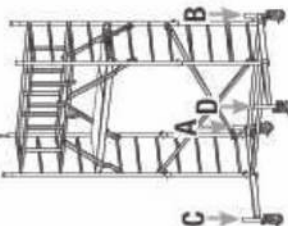
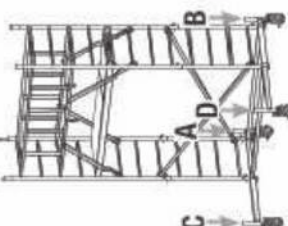
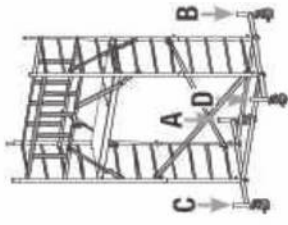
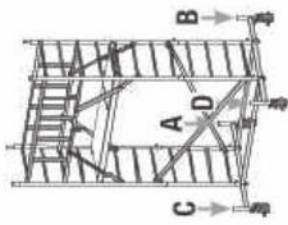
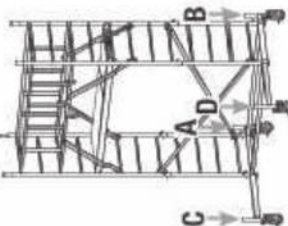
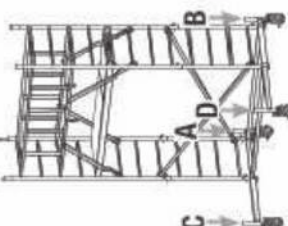
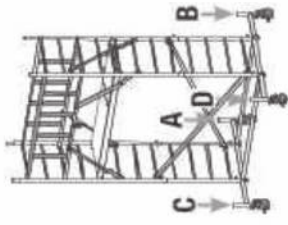
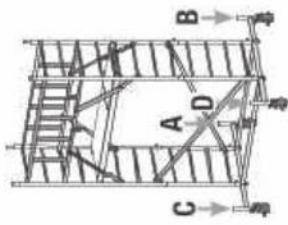
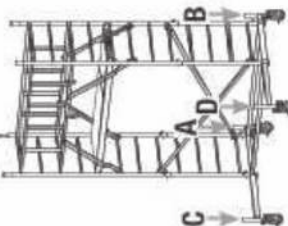
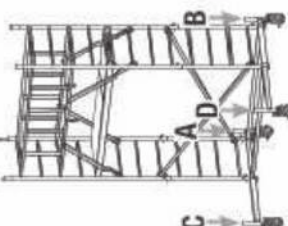
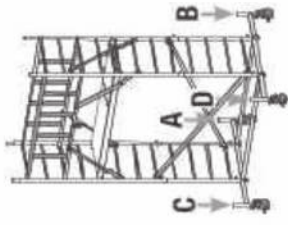
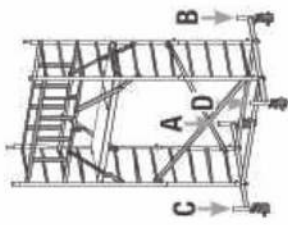
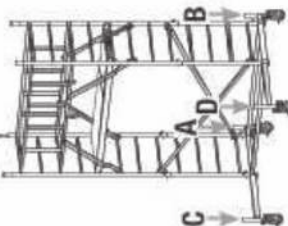
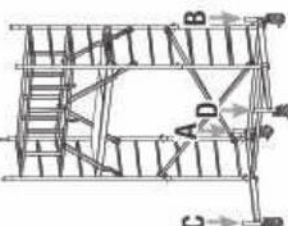
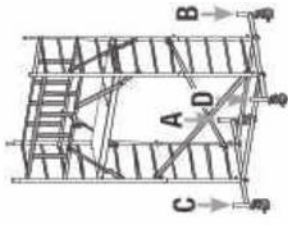
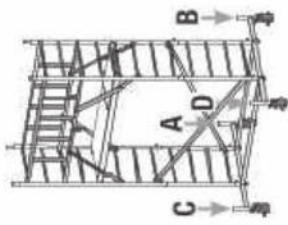
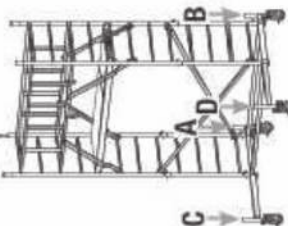
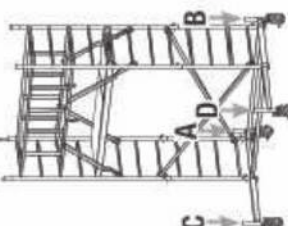
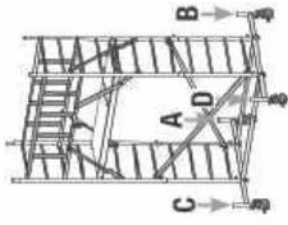
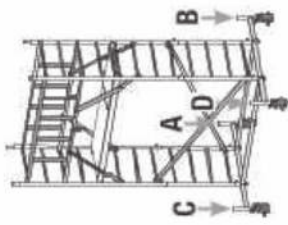
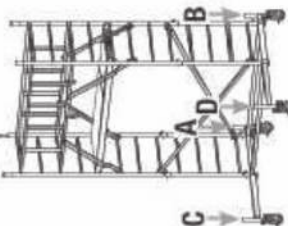
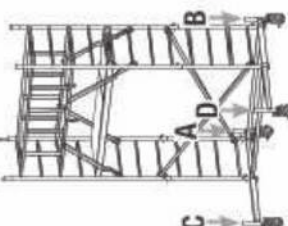
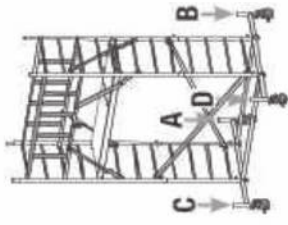
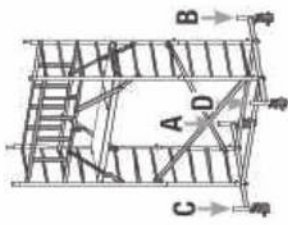
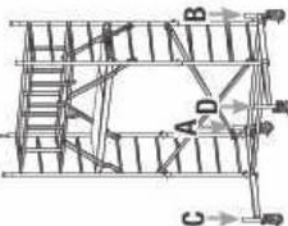
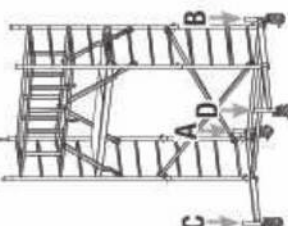
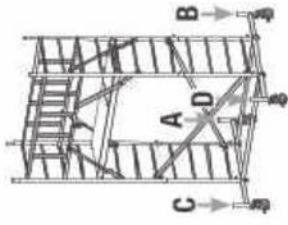
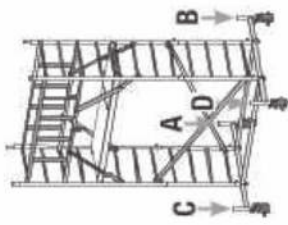
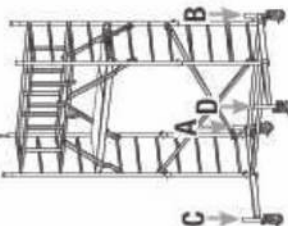
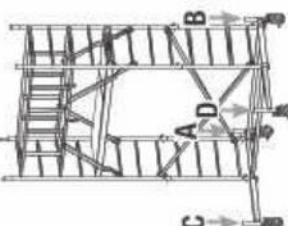
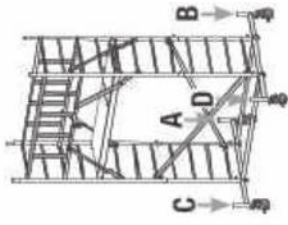
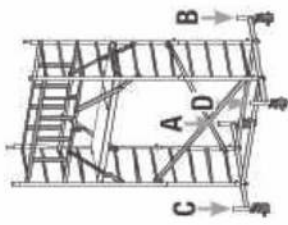
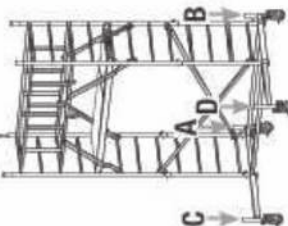
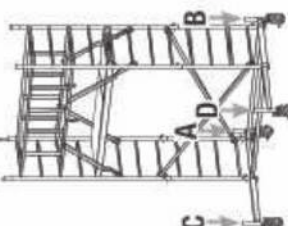
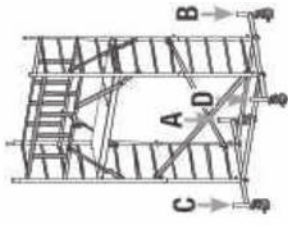
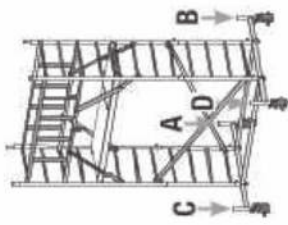
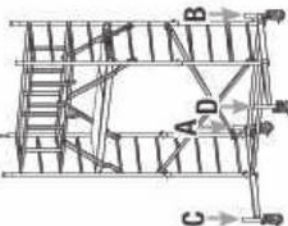
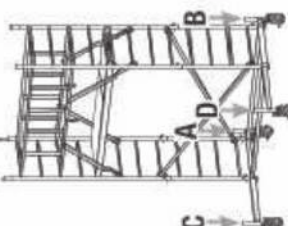
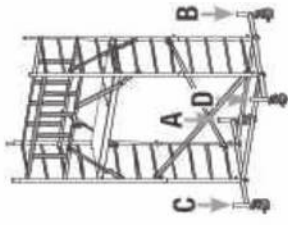
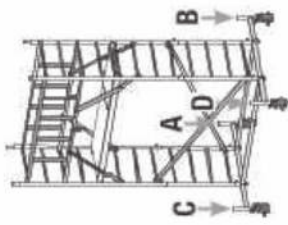
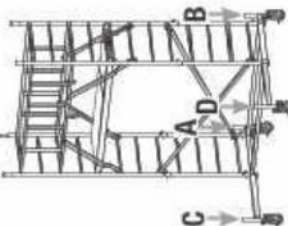
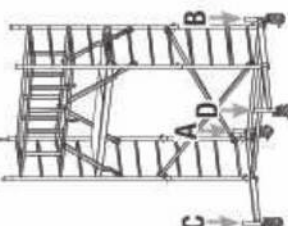
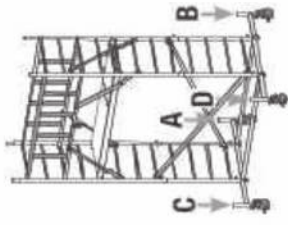
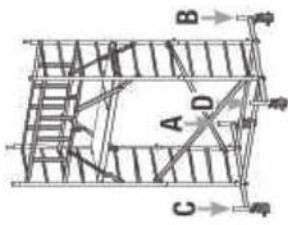
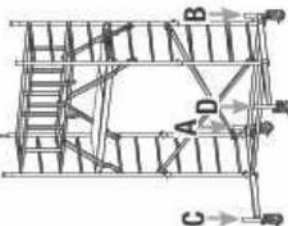
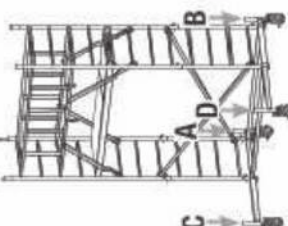
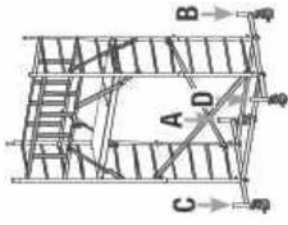
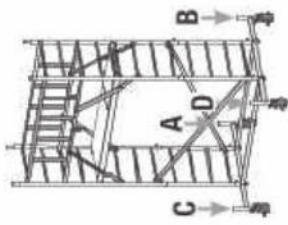
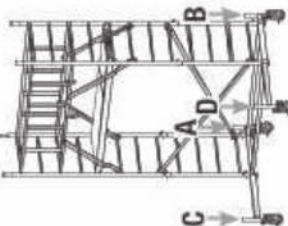
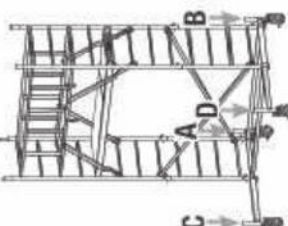
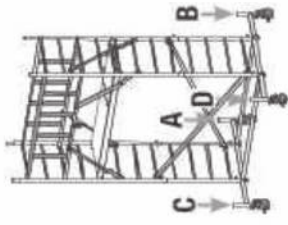
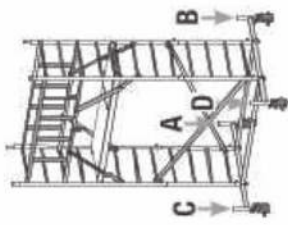
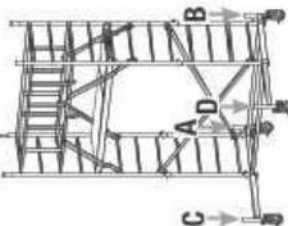
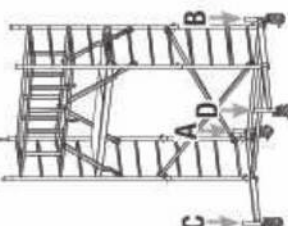
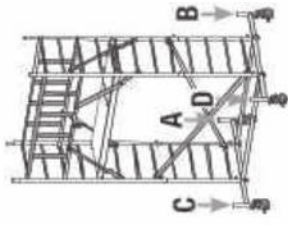
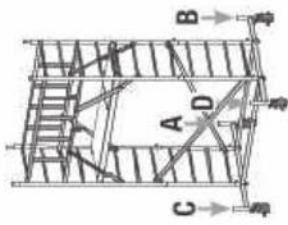
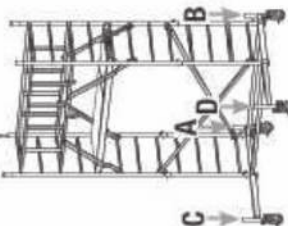
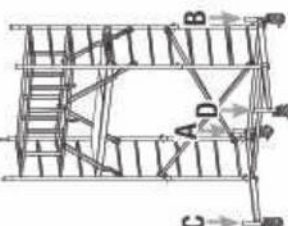
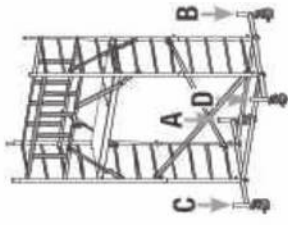
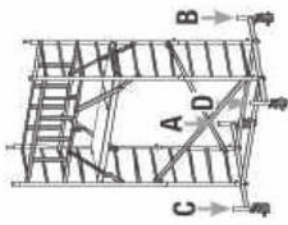
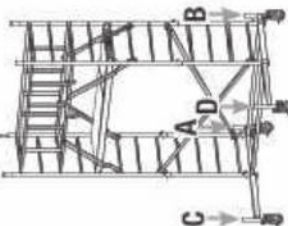
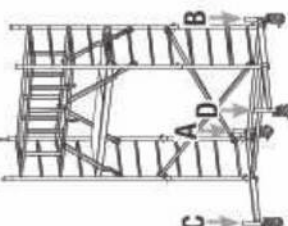
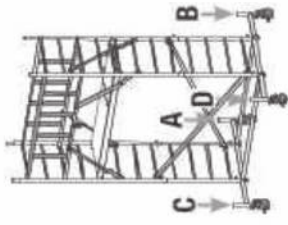
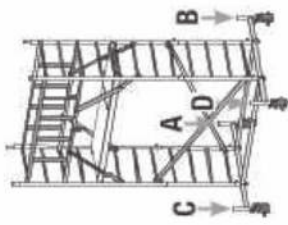
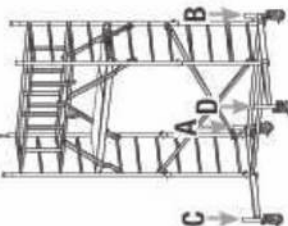
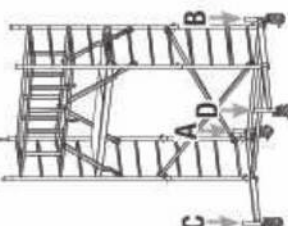
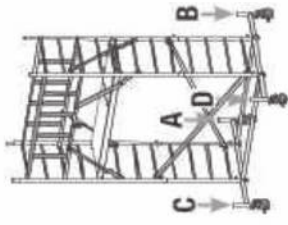
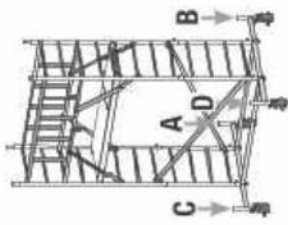
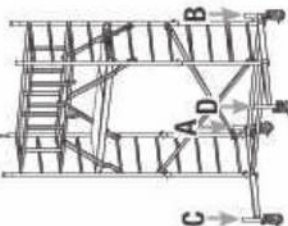
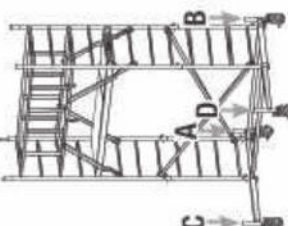
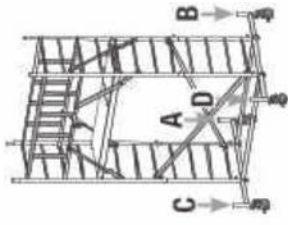
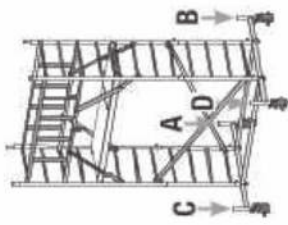

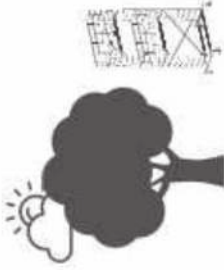
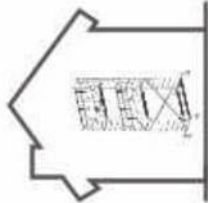
	A	B	C	D	A	B	C	D
< 2,90	0	0	0	0	0	0	0	0

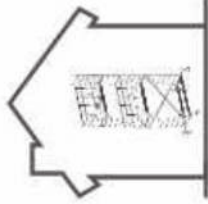
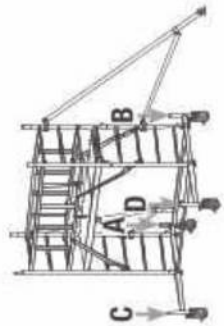
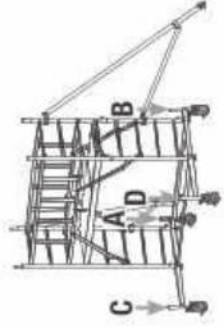
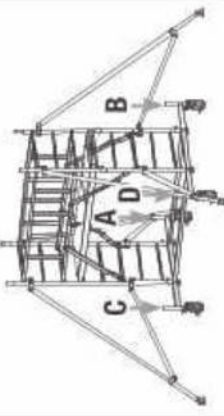
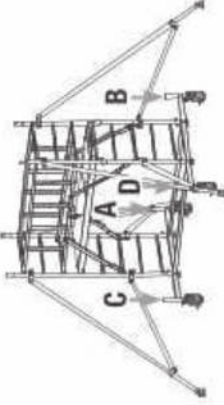
14.

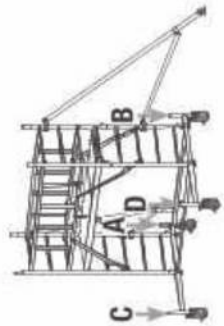
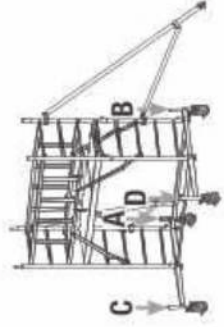
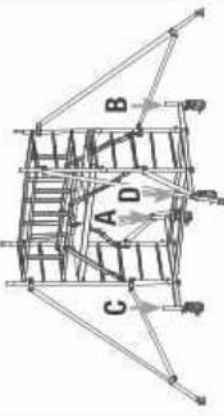
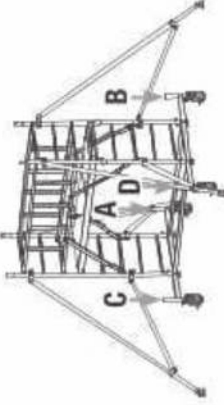
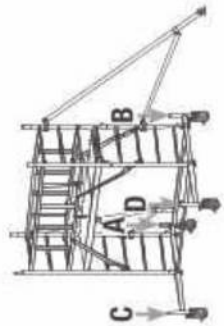
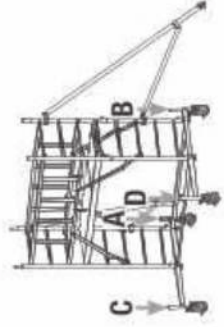
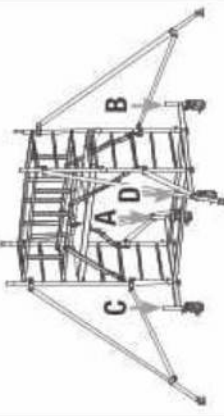
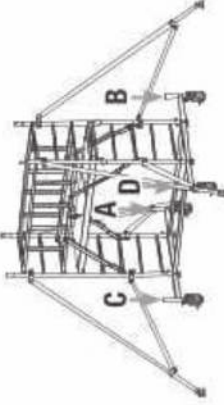
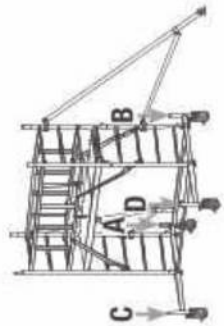
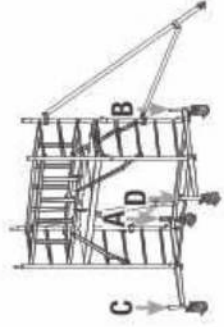
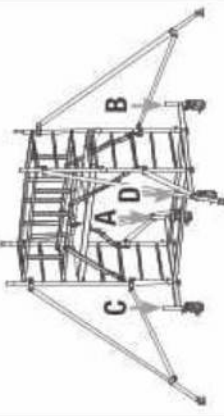
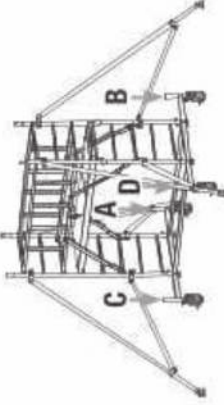
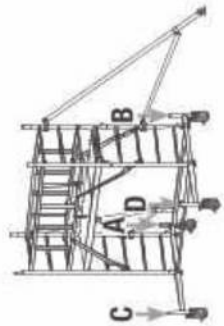
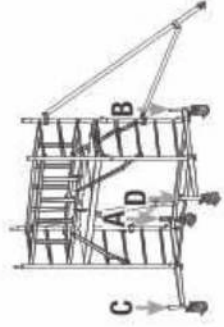
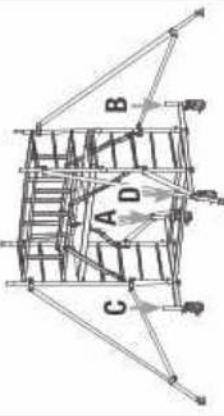
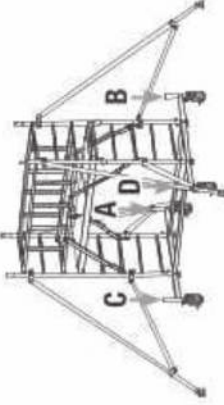
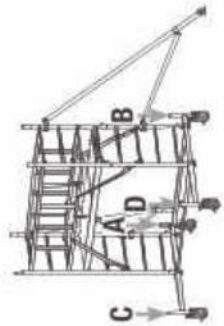
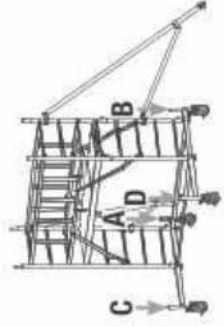
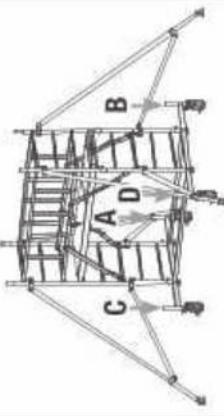
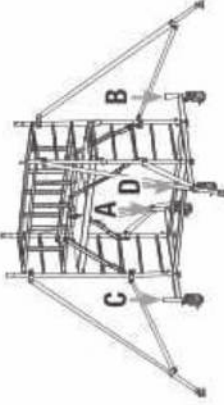
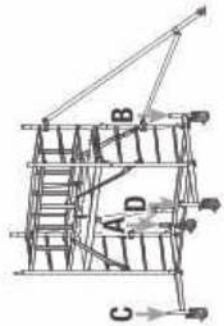
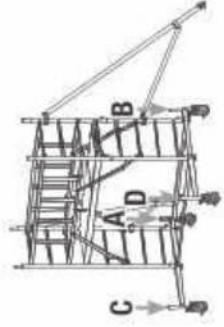
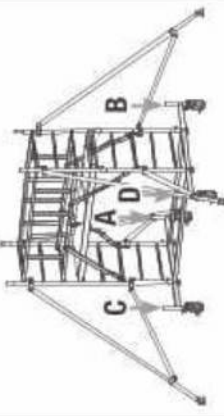
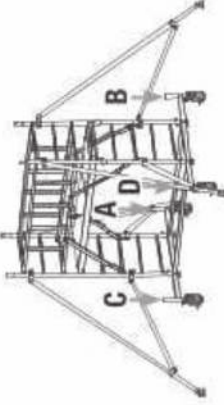
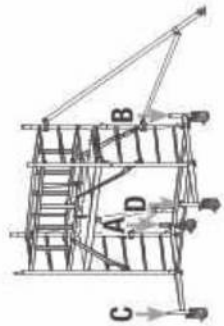
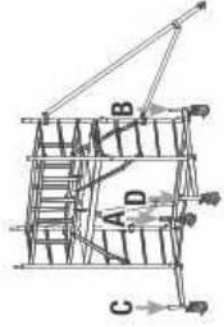
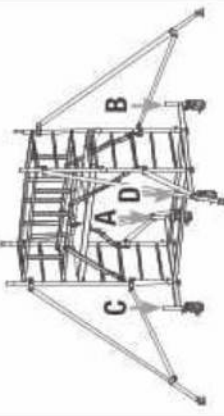
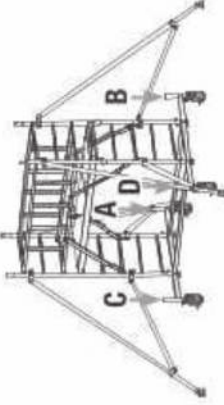
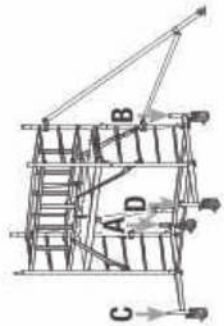
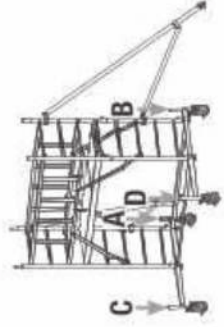
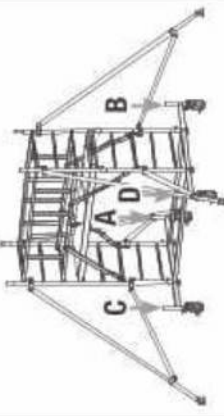
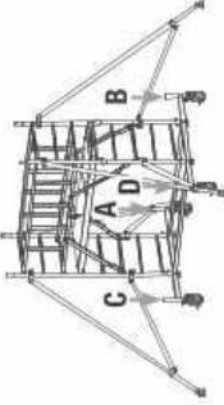
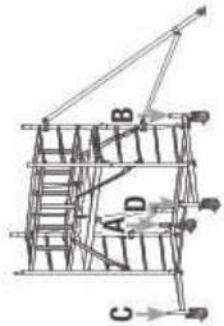
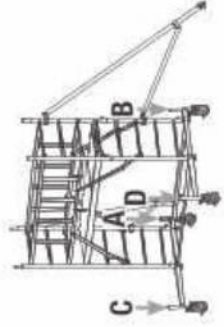
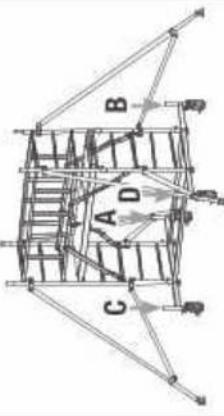
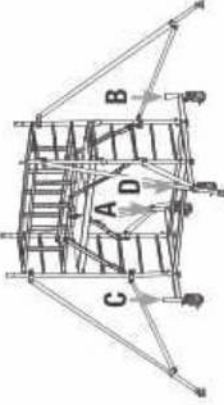
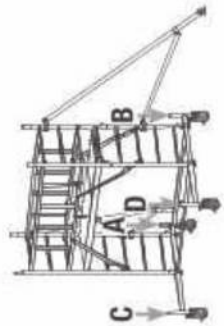
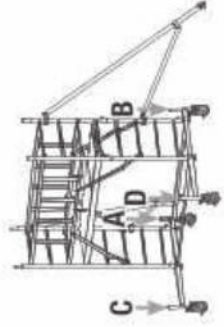
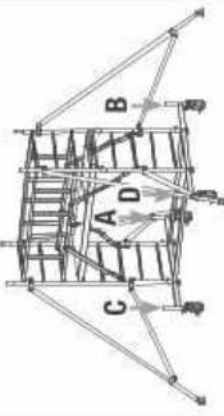
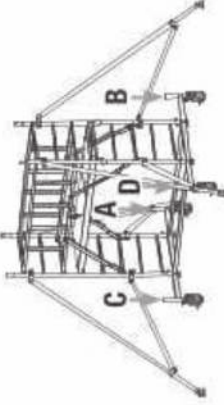
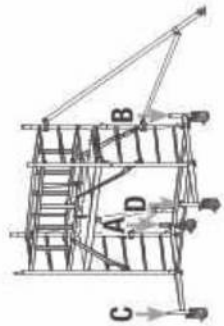
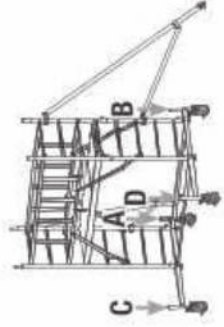
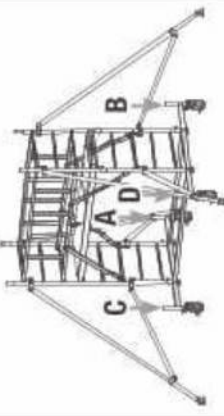
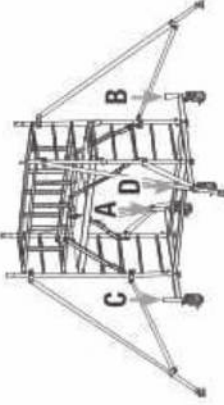
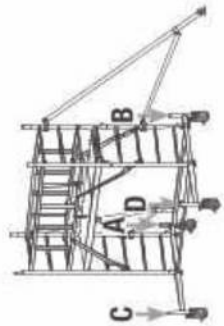
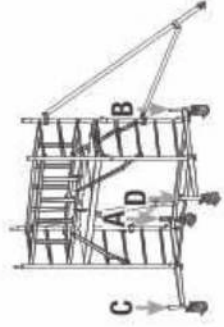
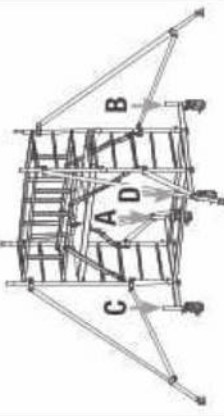
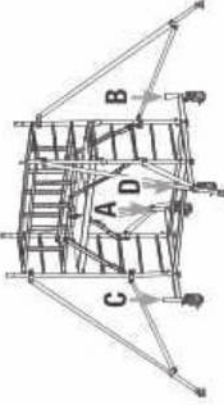
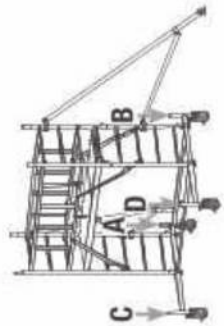
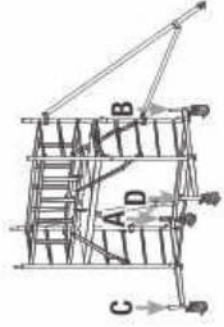
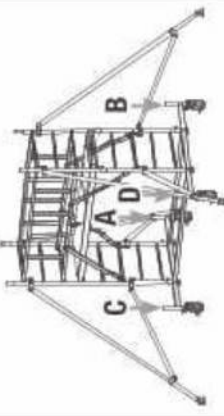
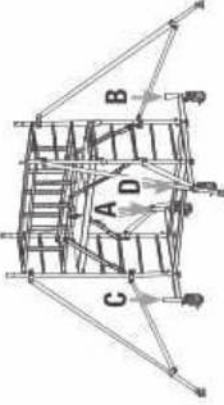
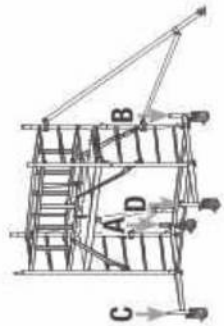
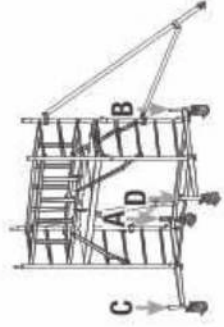
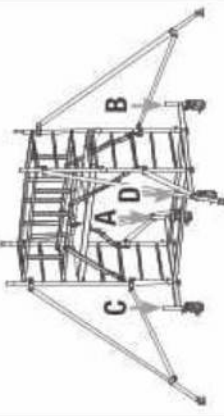
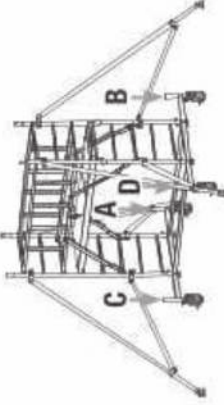
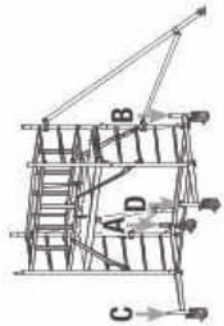
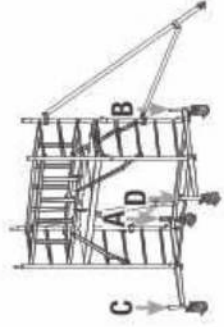
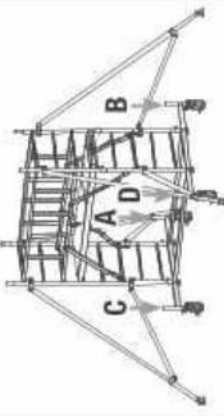
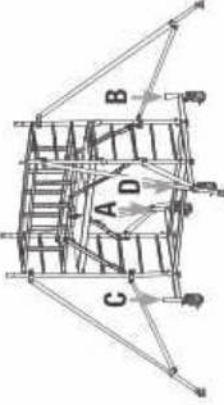
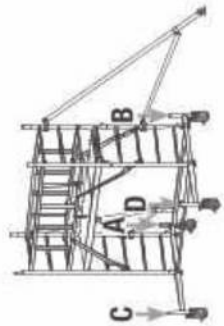
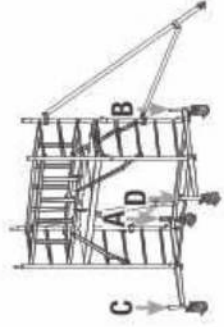
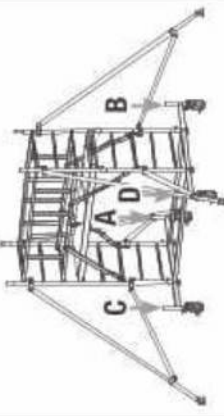
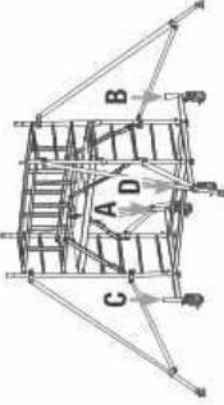
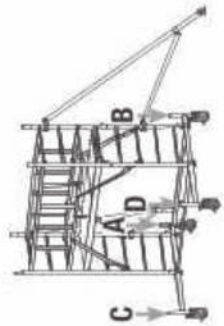
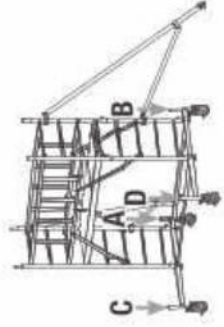
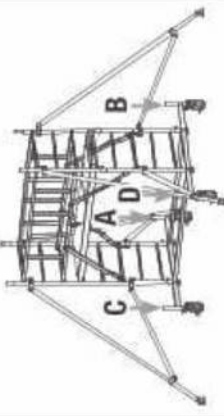
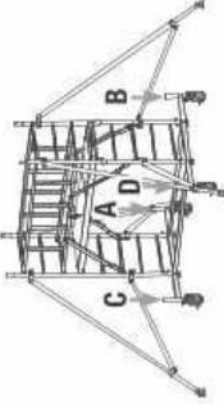
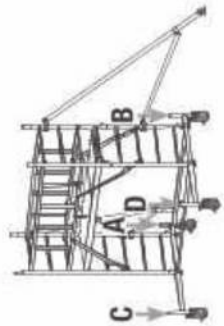
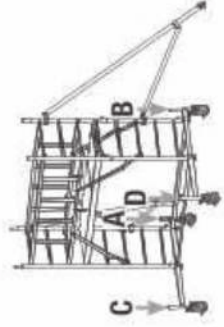
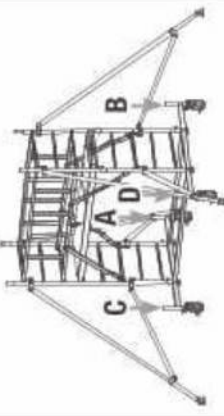
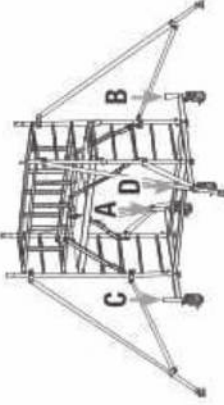
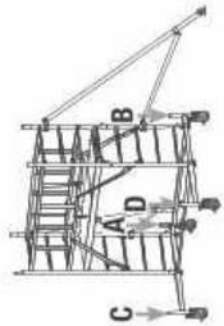
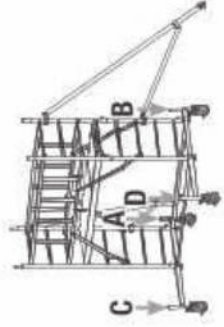
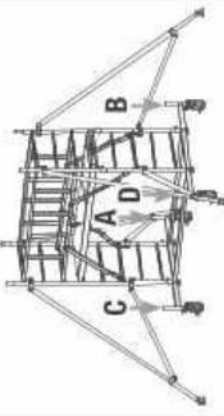
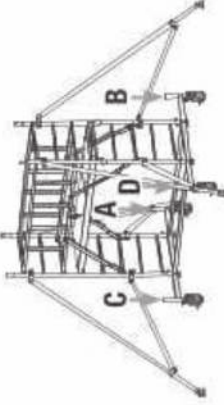
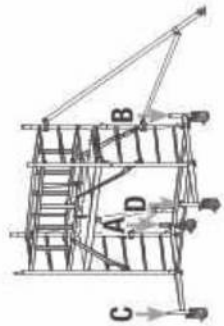
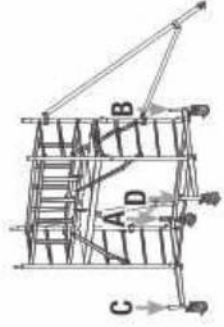
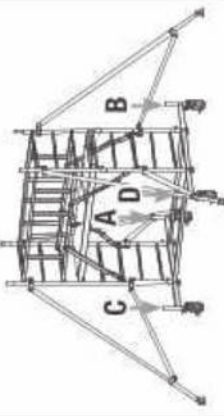
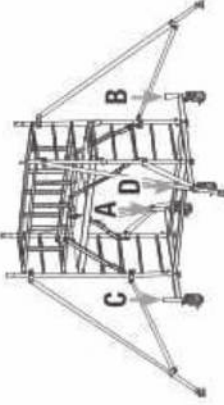
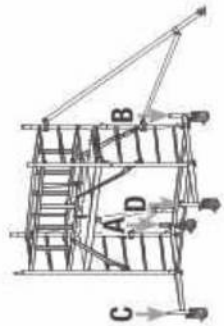
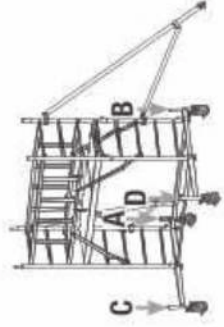
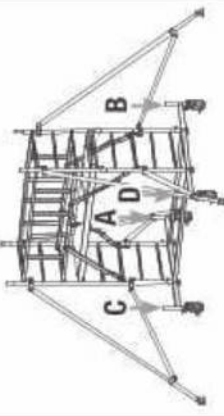
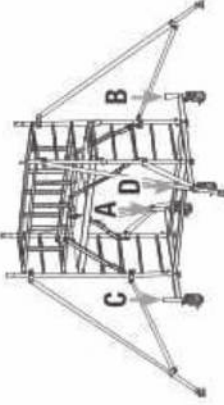
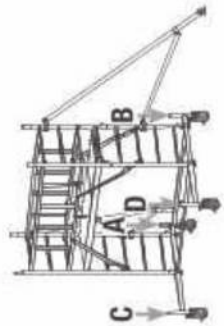
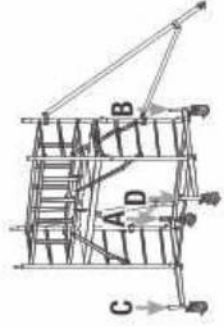
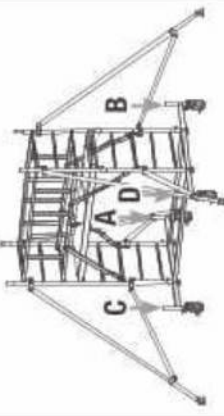
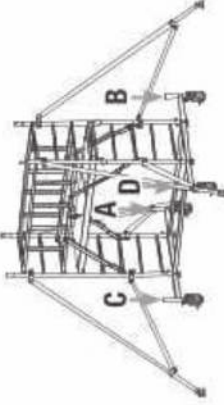
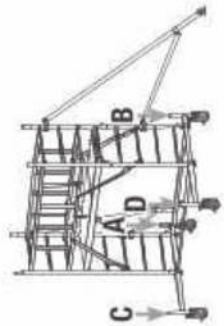
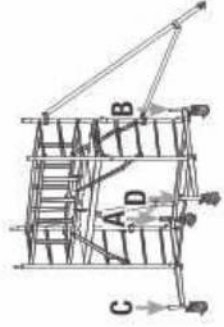
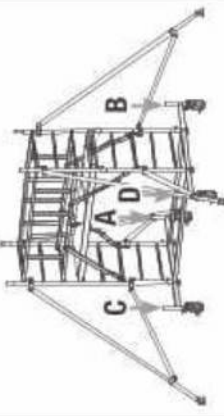
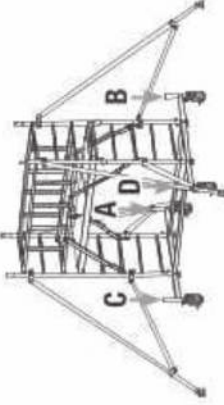
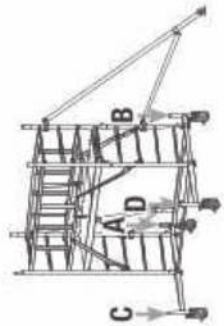
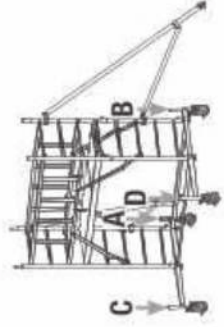
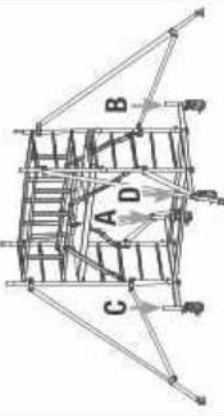
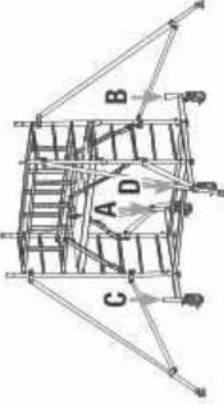
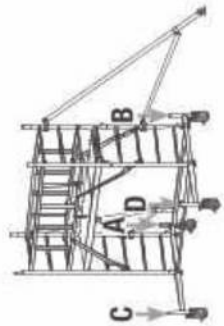
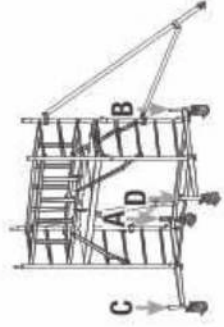
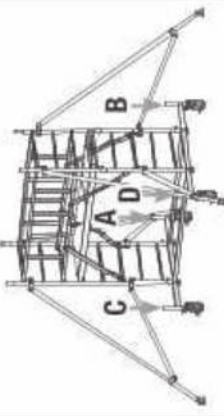
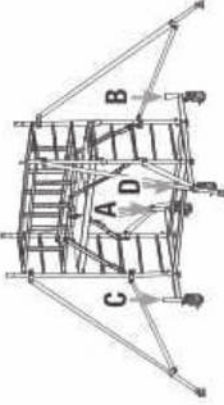
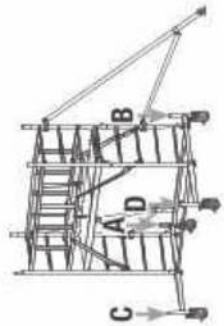
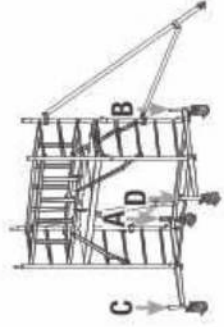
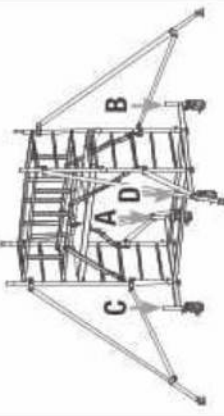
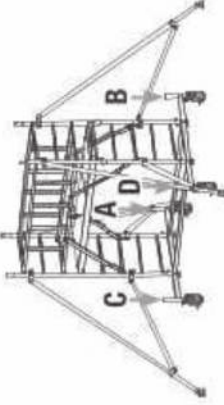
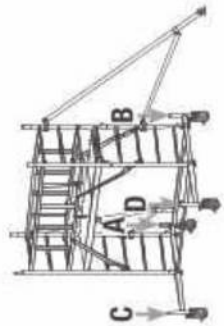
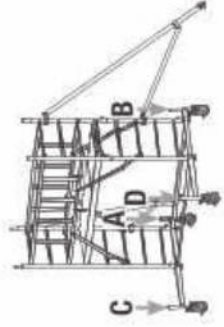
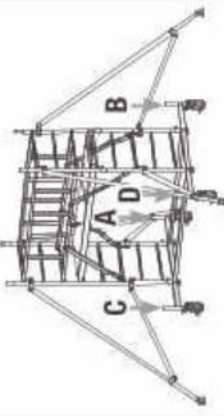
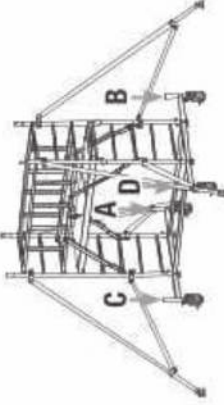
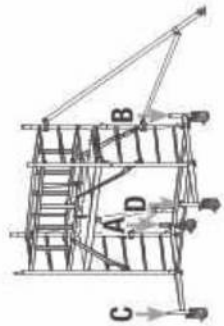
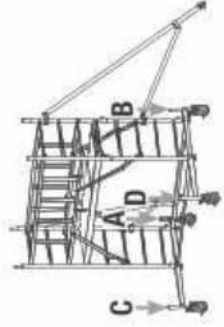
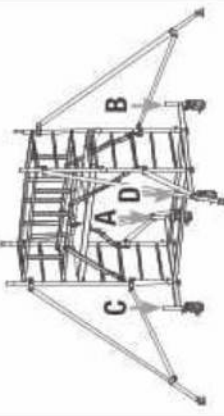
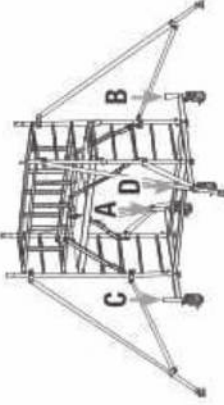
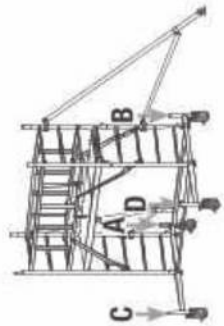
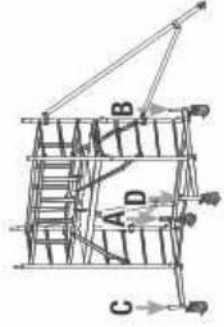
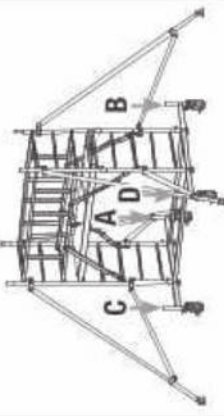
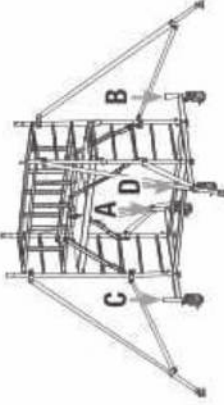
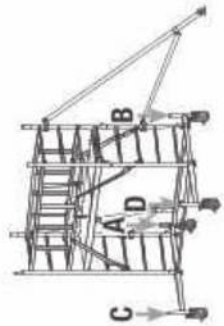
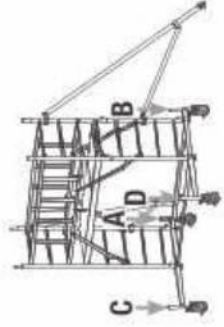
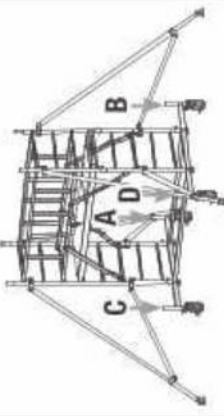
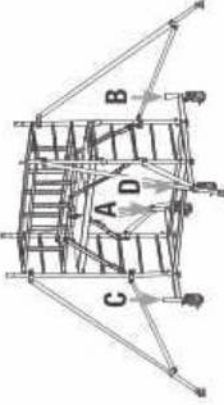
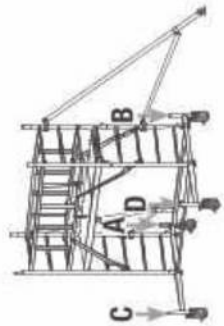
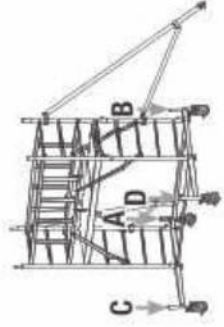
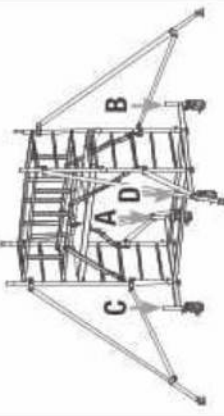
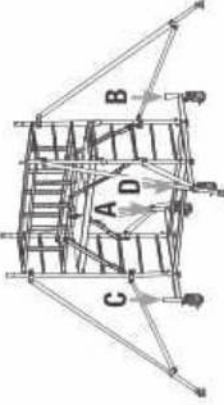
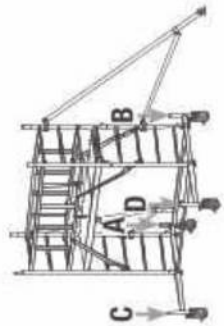
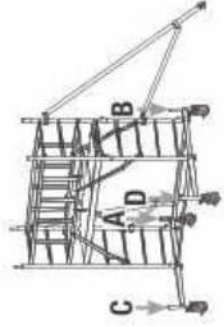
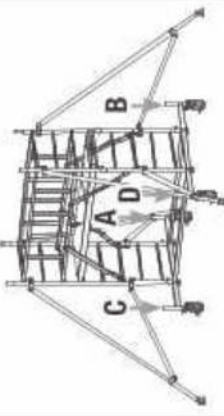
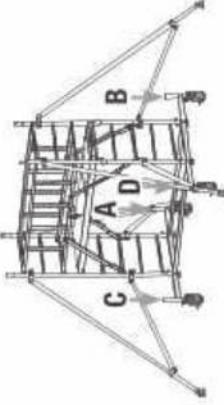
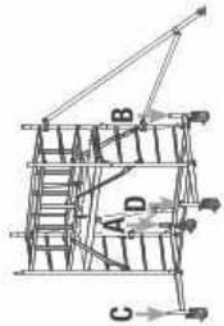
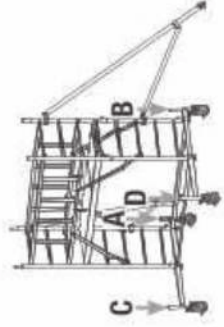
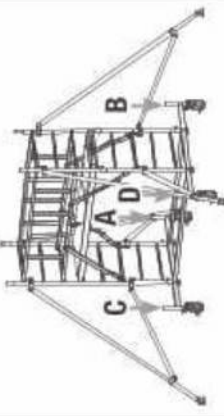
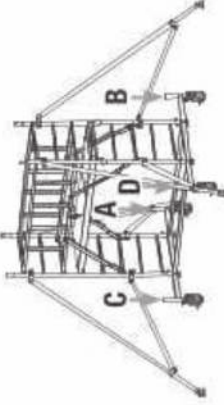
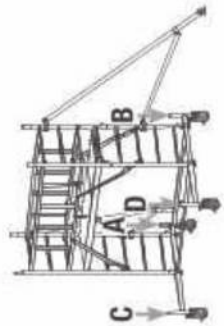
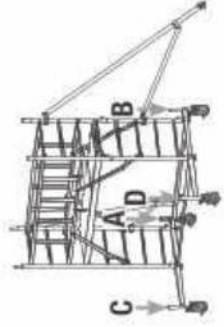
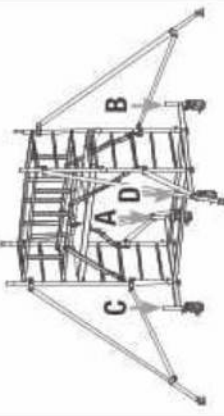
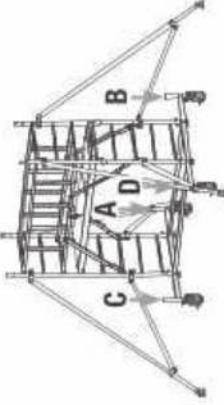
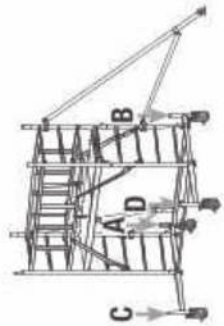
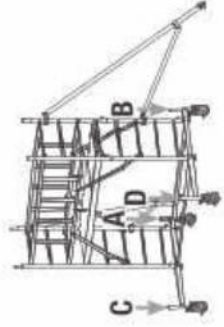
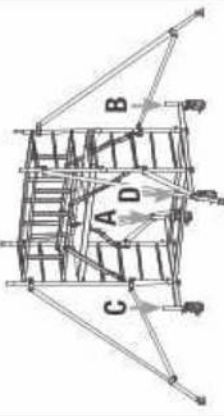
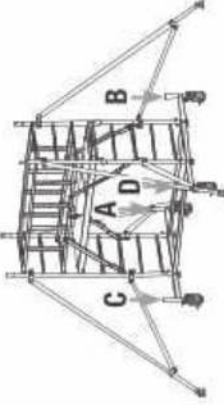
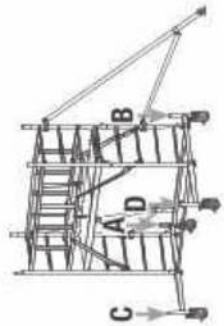
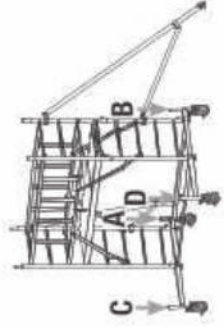
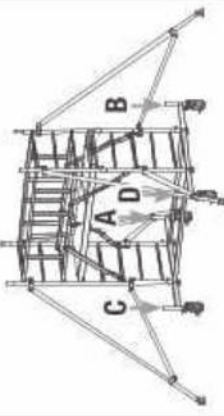
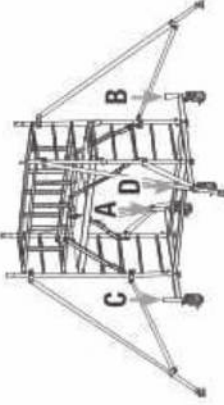
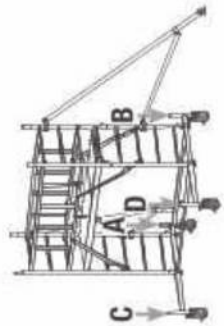
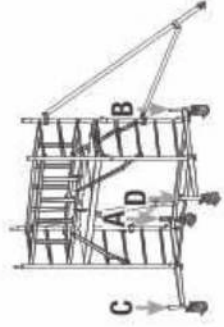
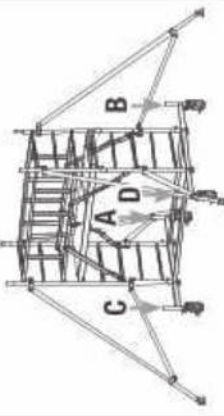
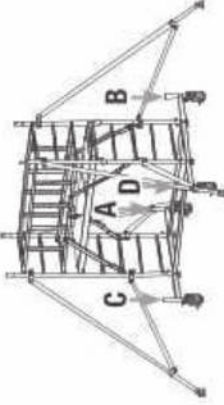
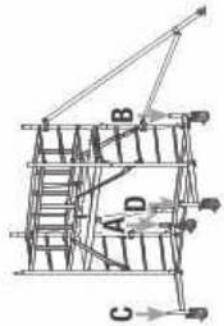
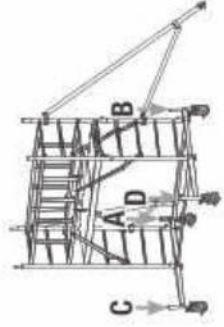
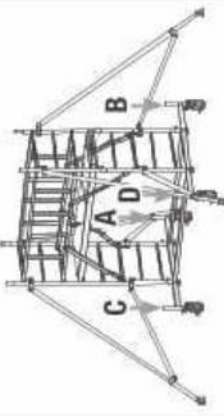
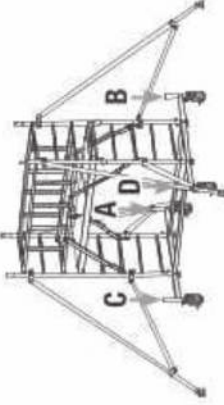
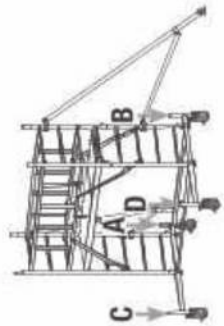
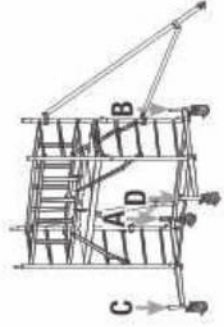
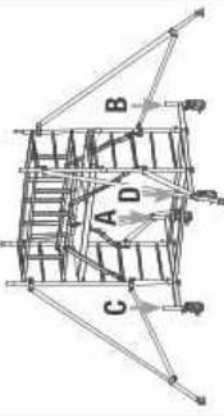
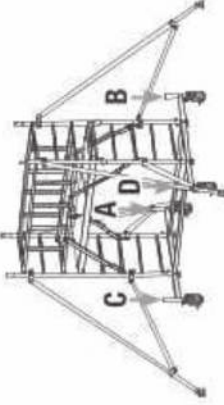
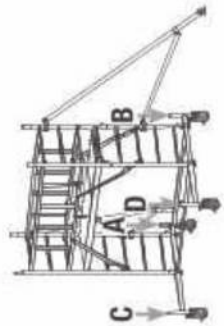
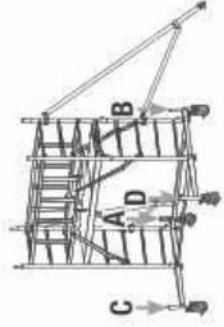
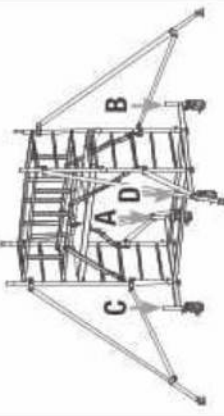
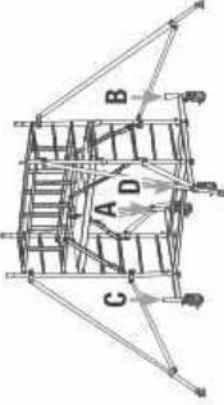
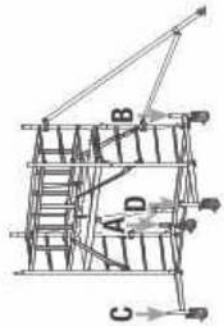
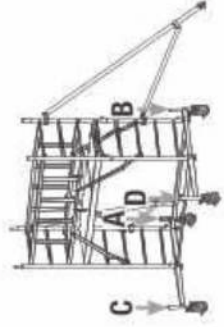
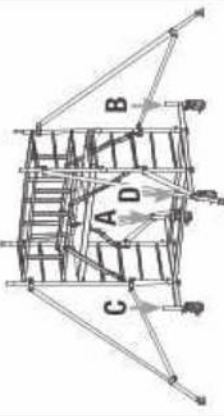
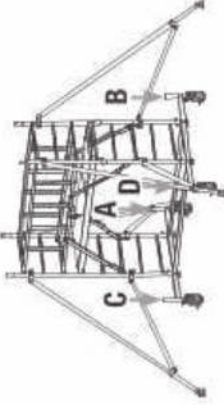
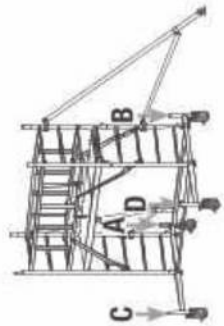
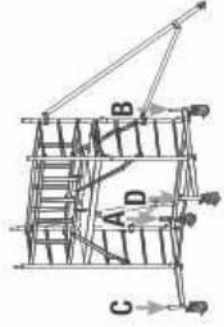
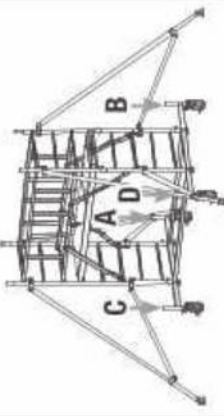
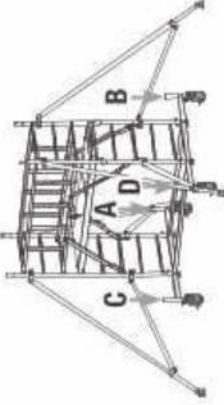
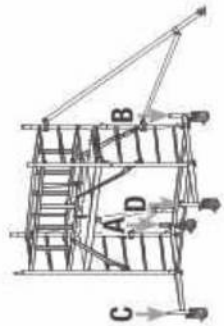
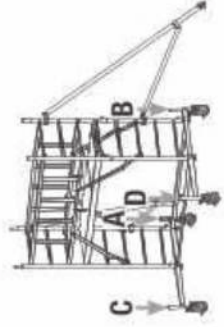
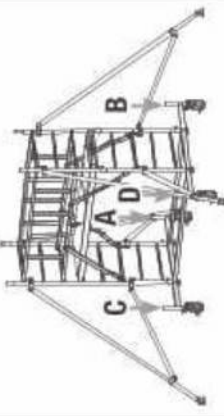
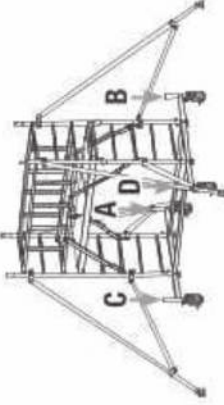
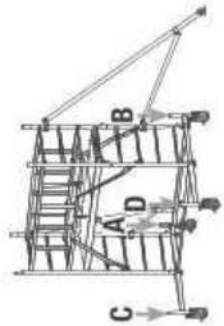
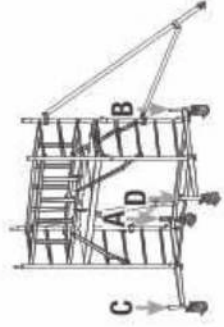
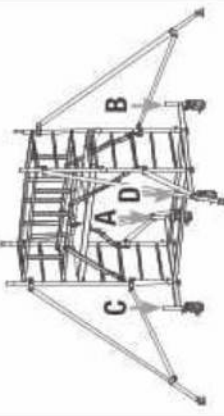
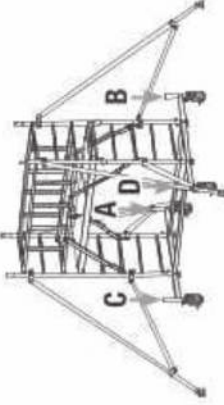
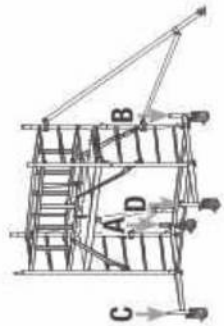
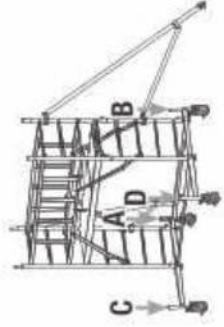
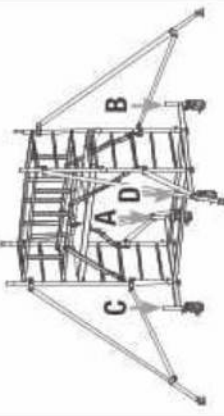
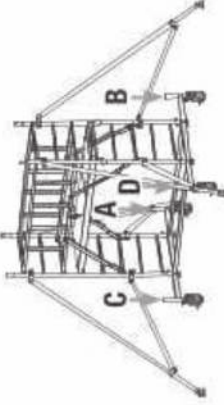
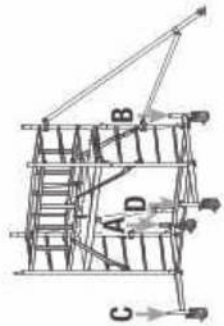
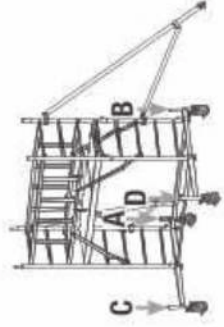
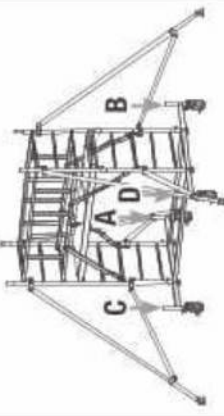
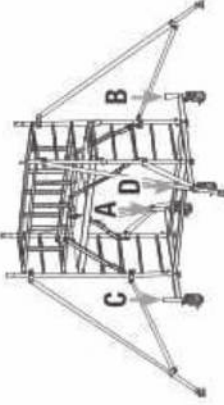
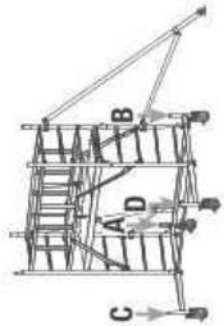
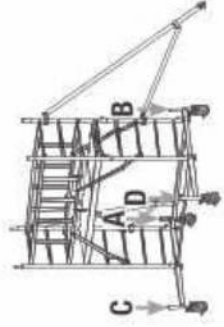
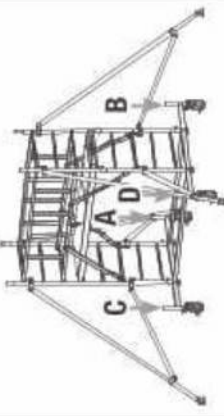
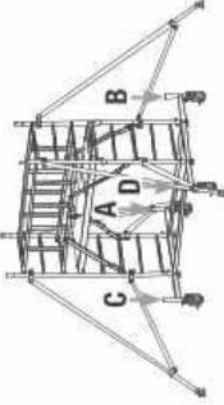
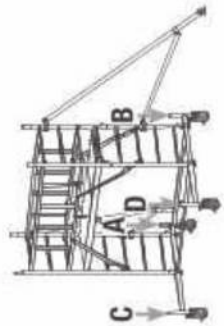
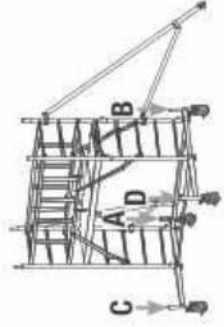
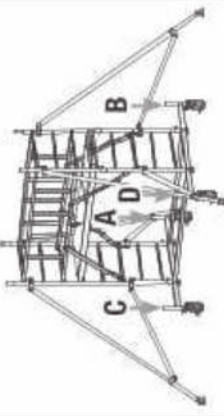
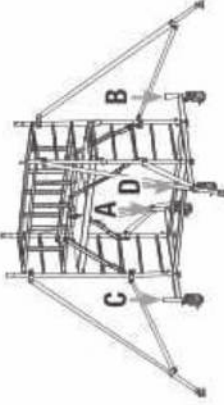
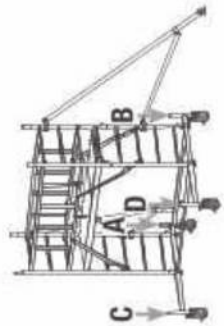
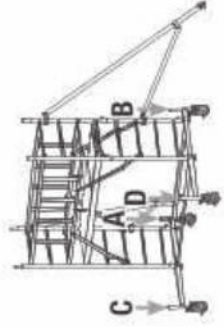
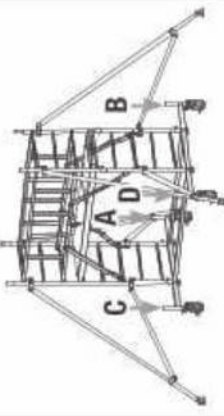
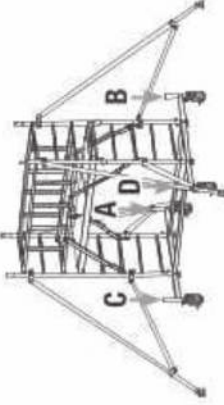
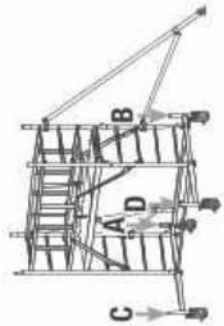
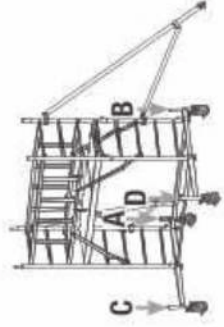
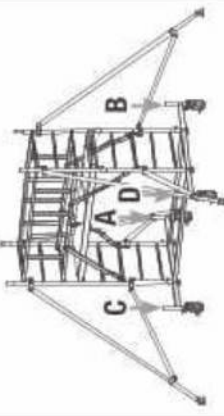
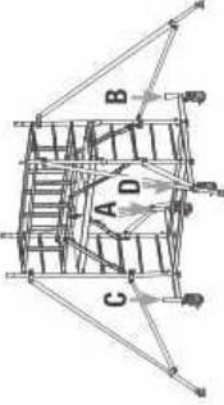
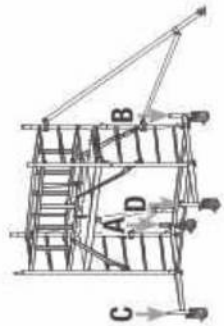
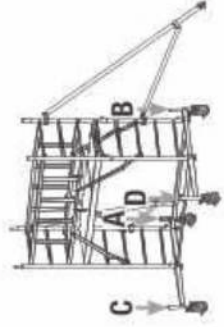
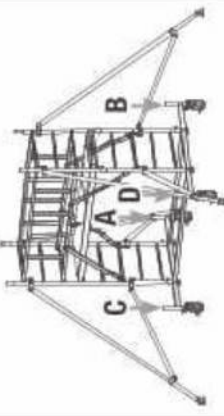
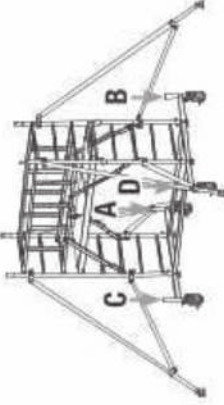
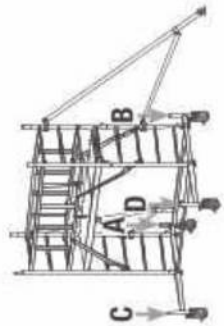
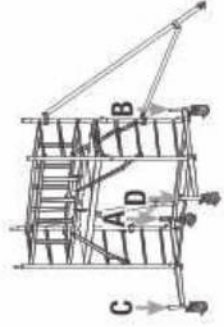
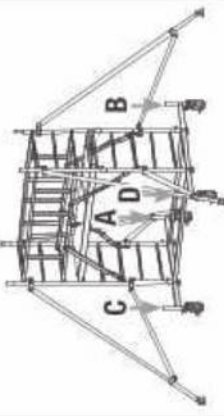
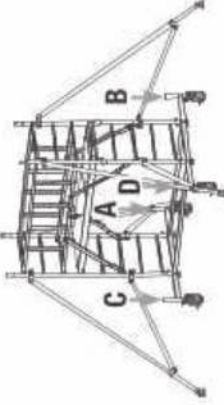
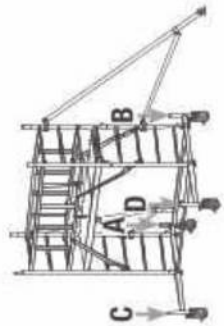
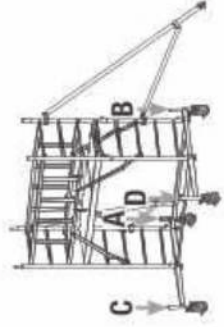
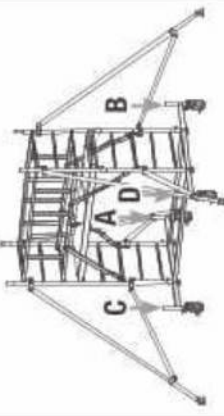
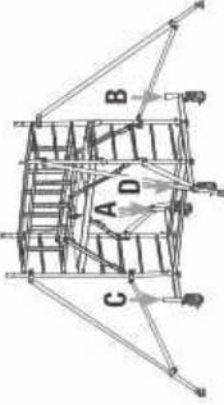
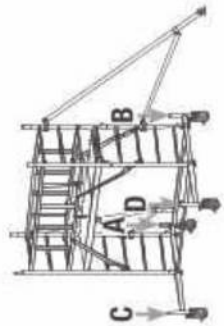
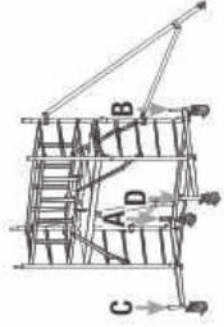
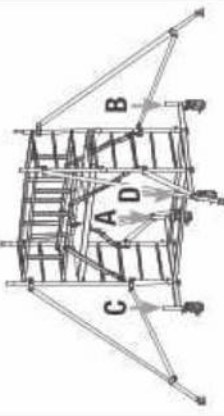
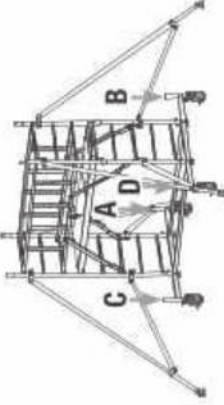
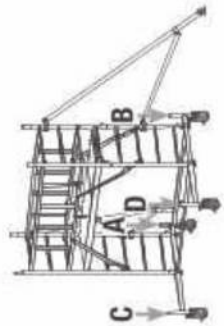
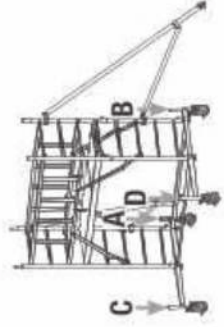
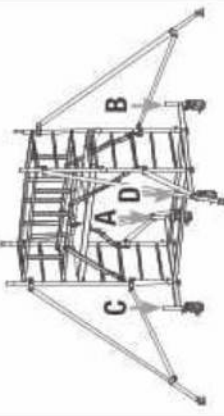
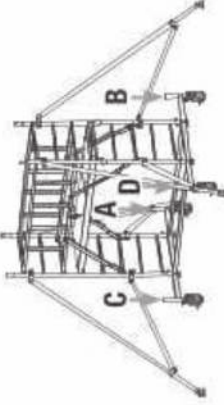
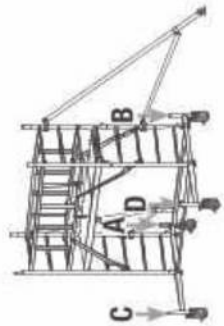
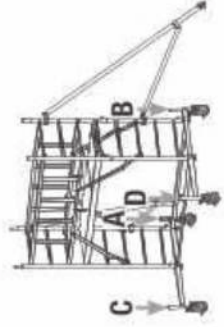
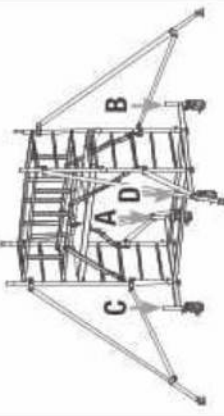
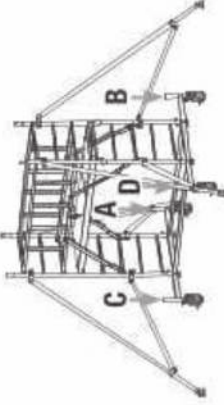
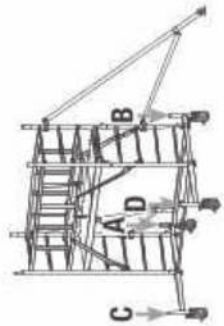
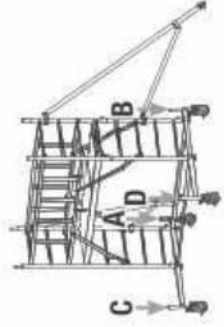
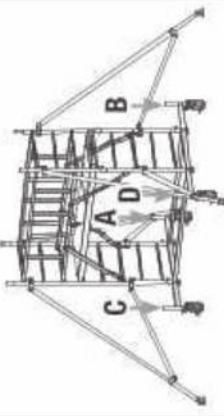
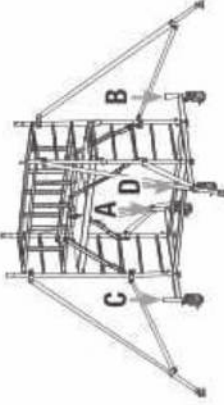
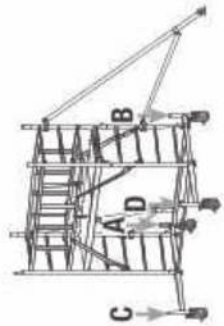
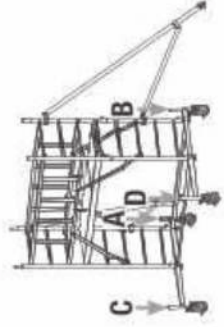
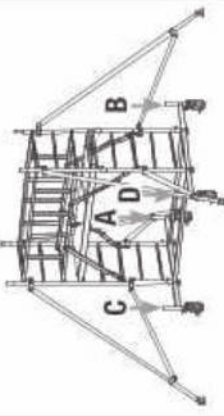
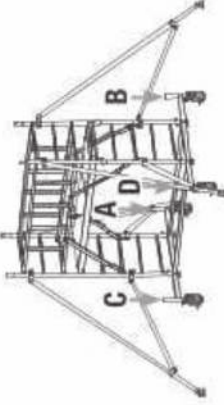
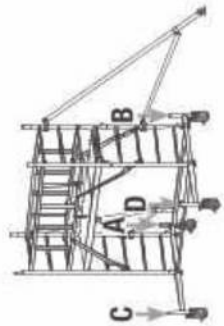
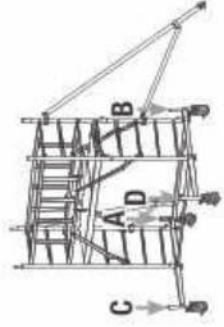
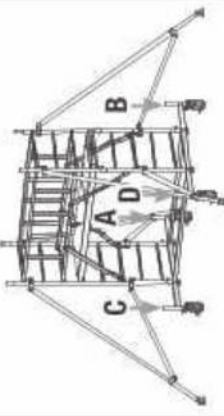
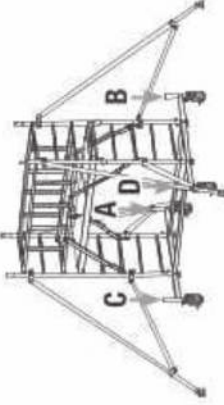
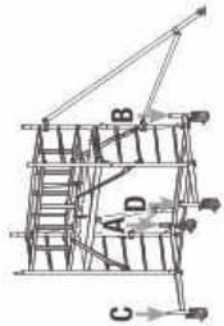
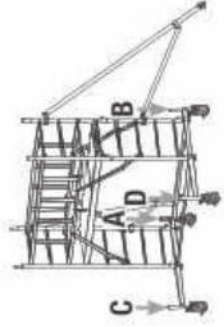
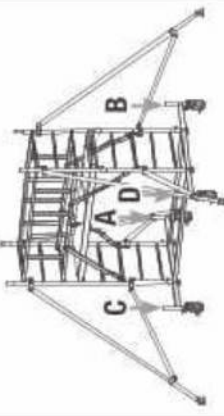
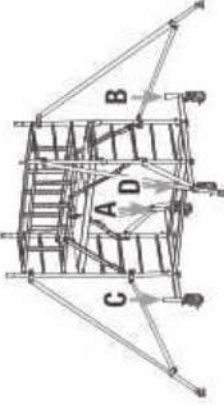
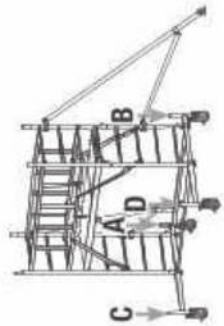
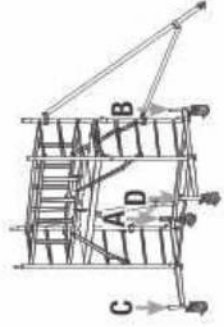
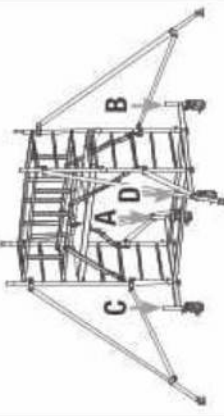
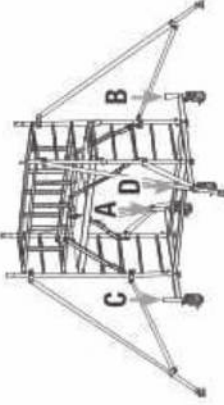
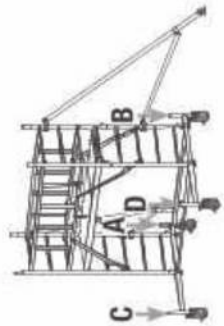
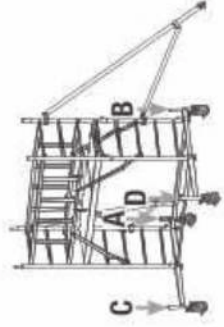
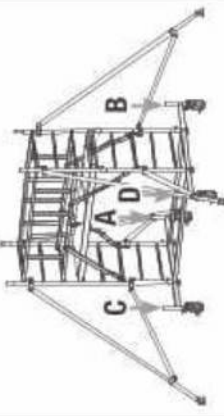
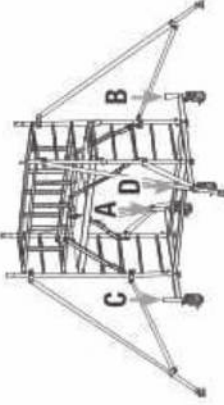
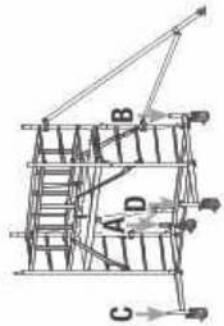
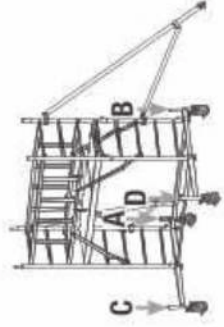
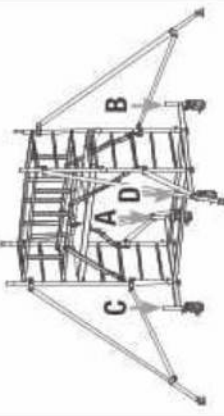
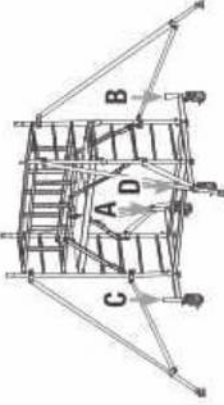
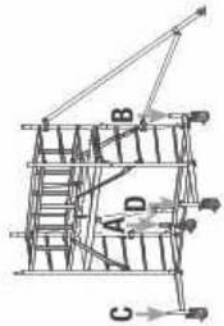
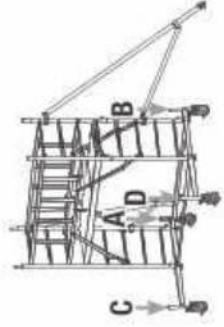
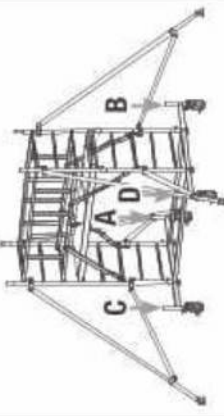
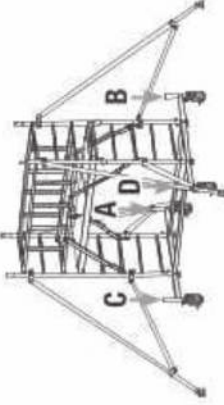
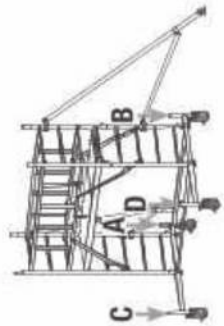
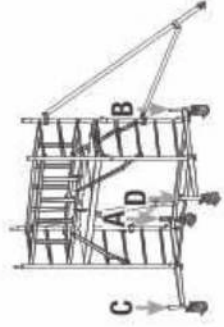
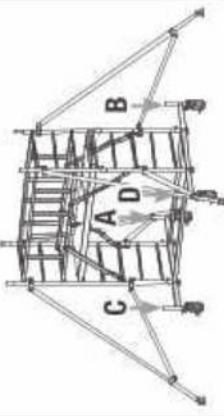
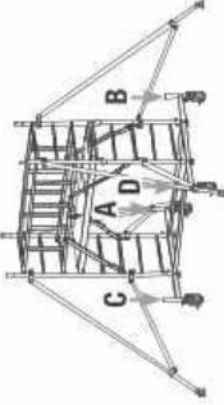
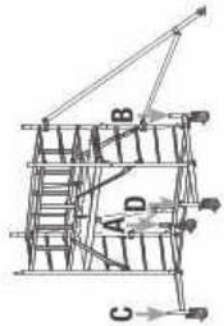
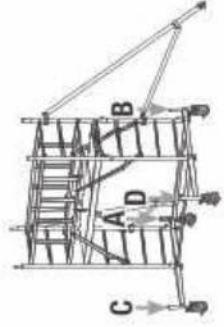
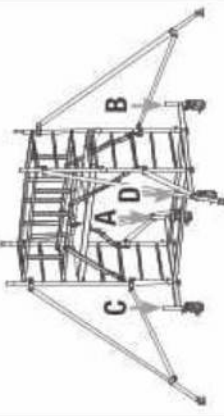
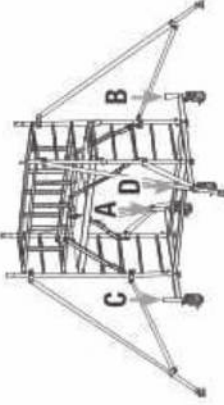
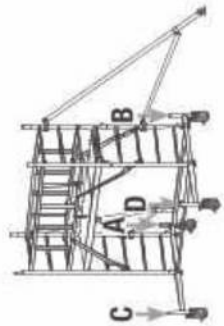
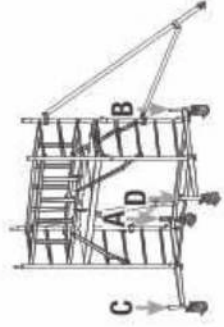
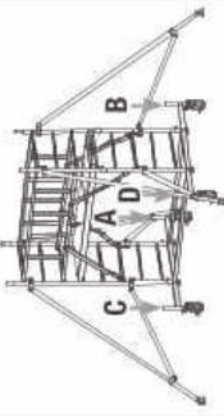
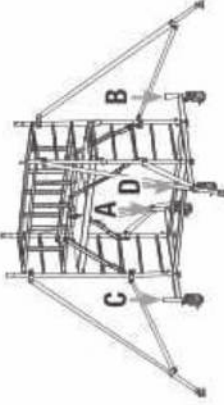
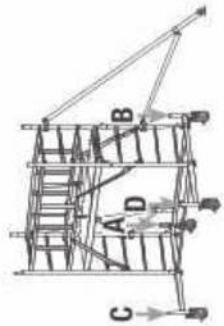
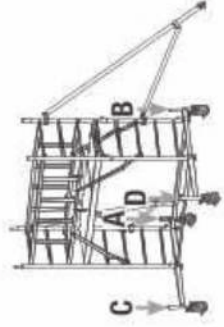
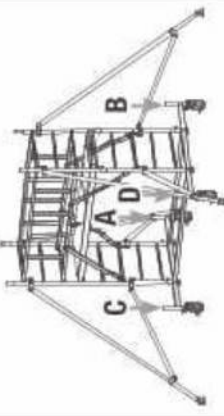
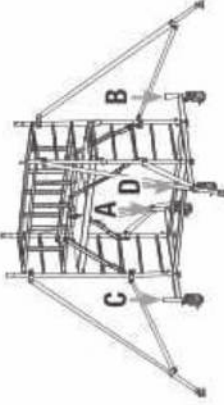
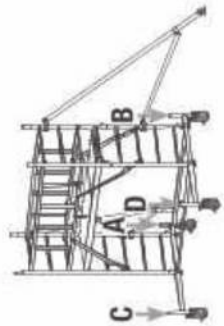
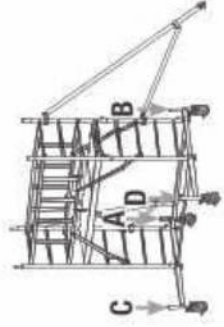
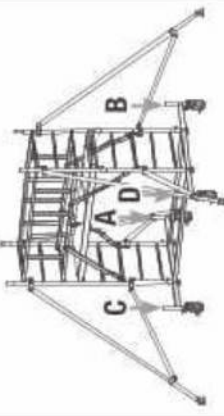
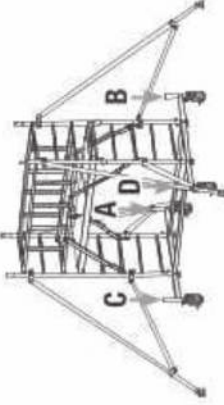
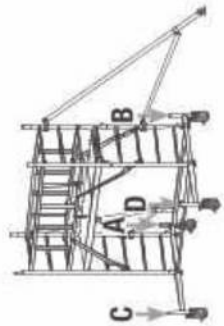
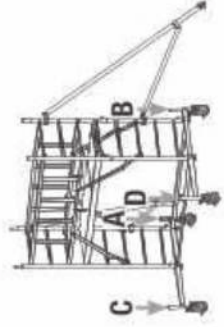
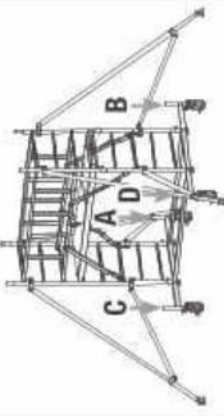
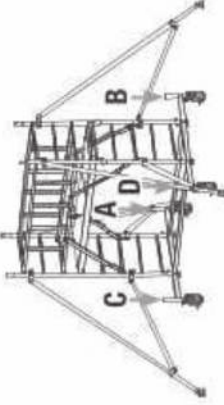
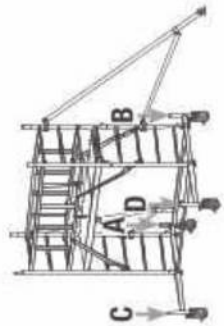
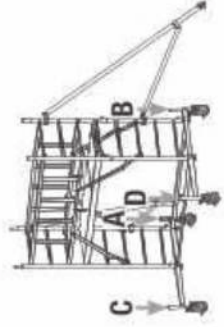
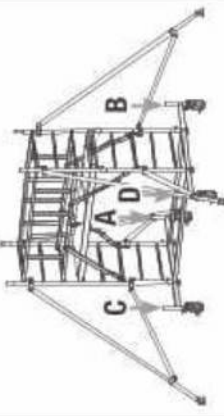
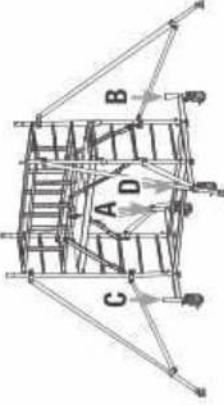
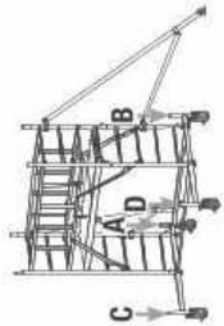
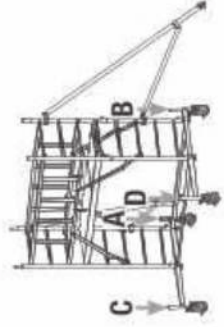
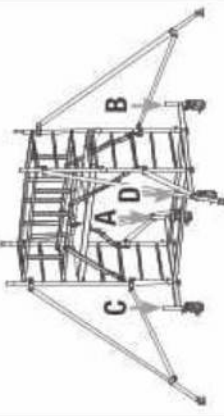
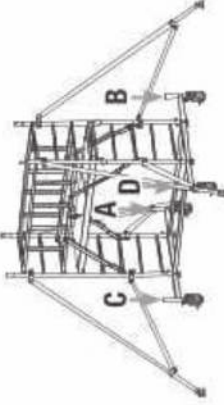
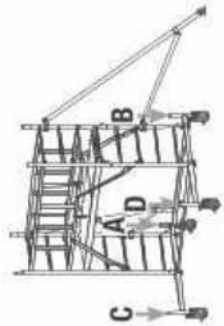
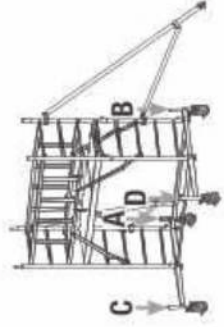
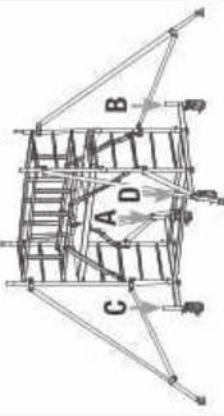
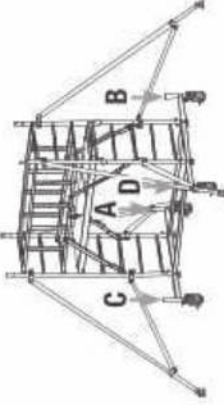
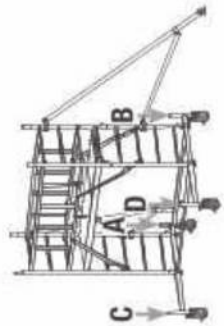
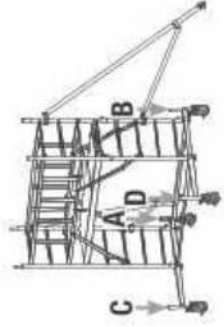
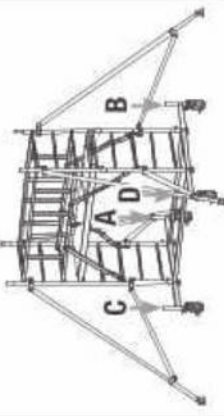
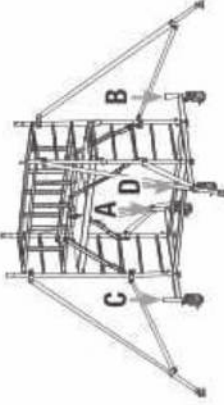
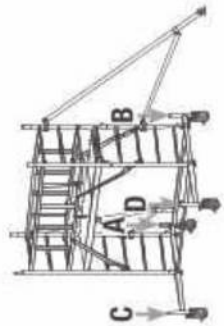
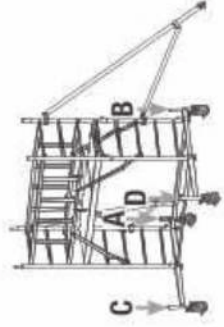
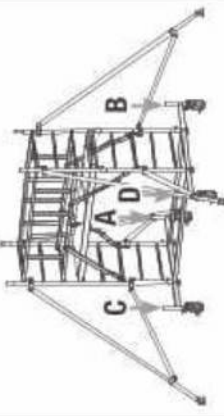
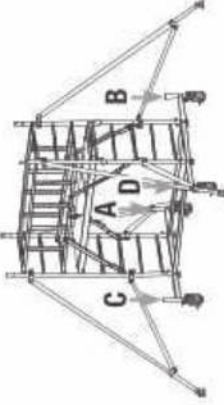
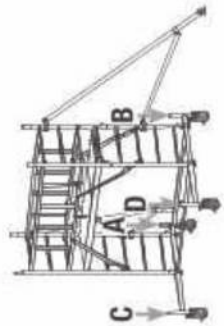
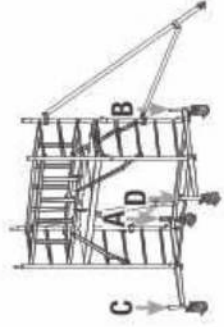
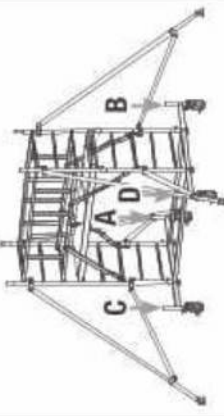
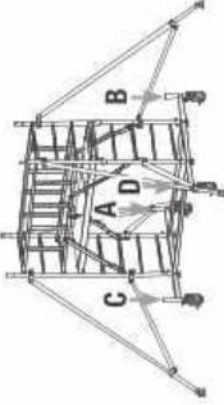
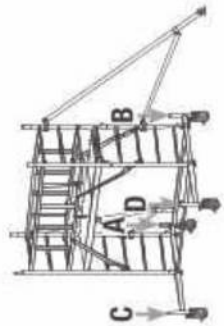
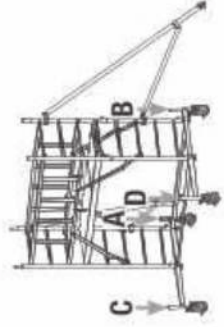
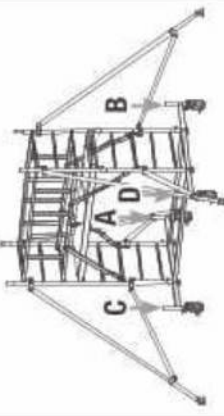
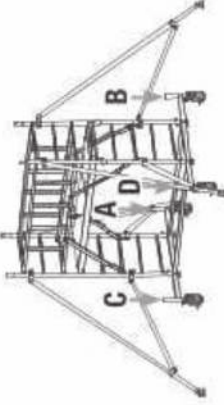
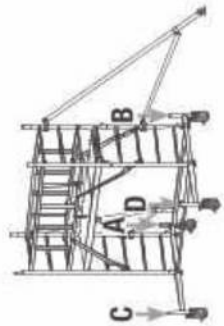
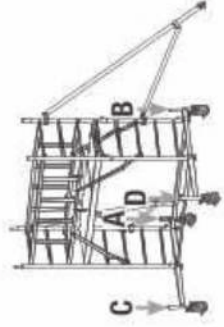
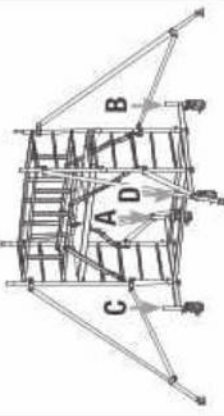
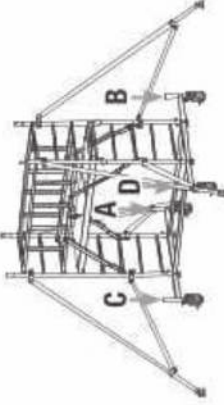
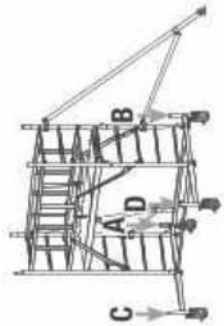
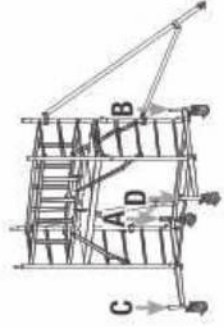
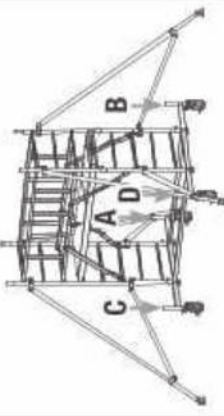
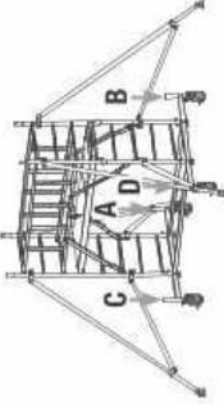
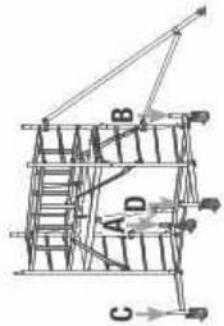
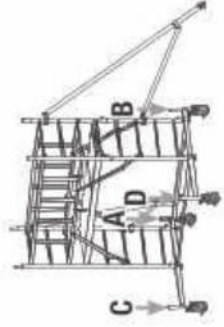
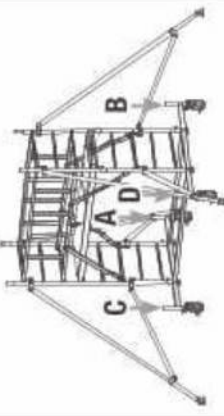
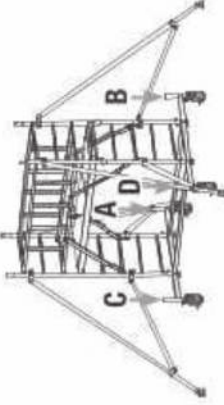
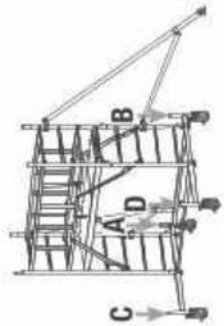
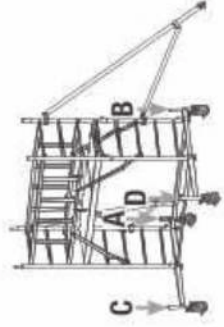
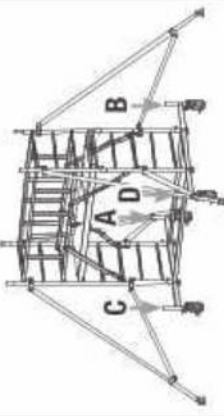
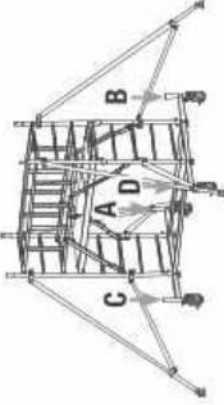
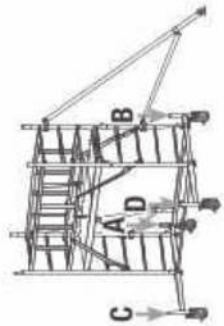
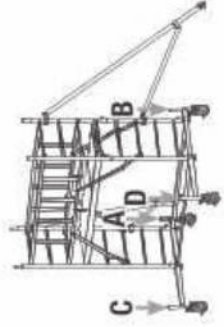
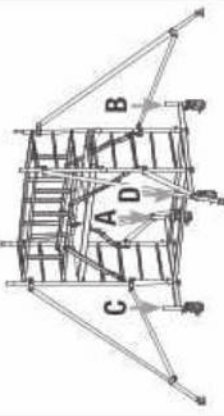
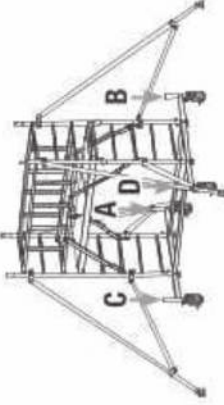
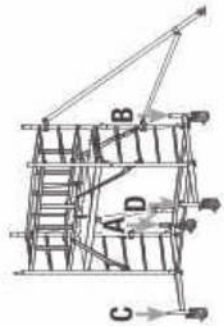
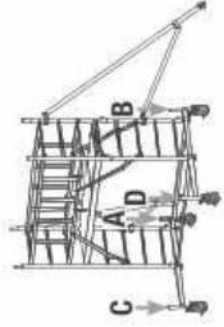
+
Extras

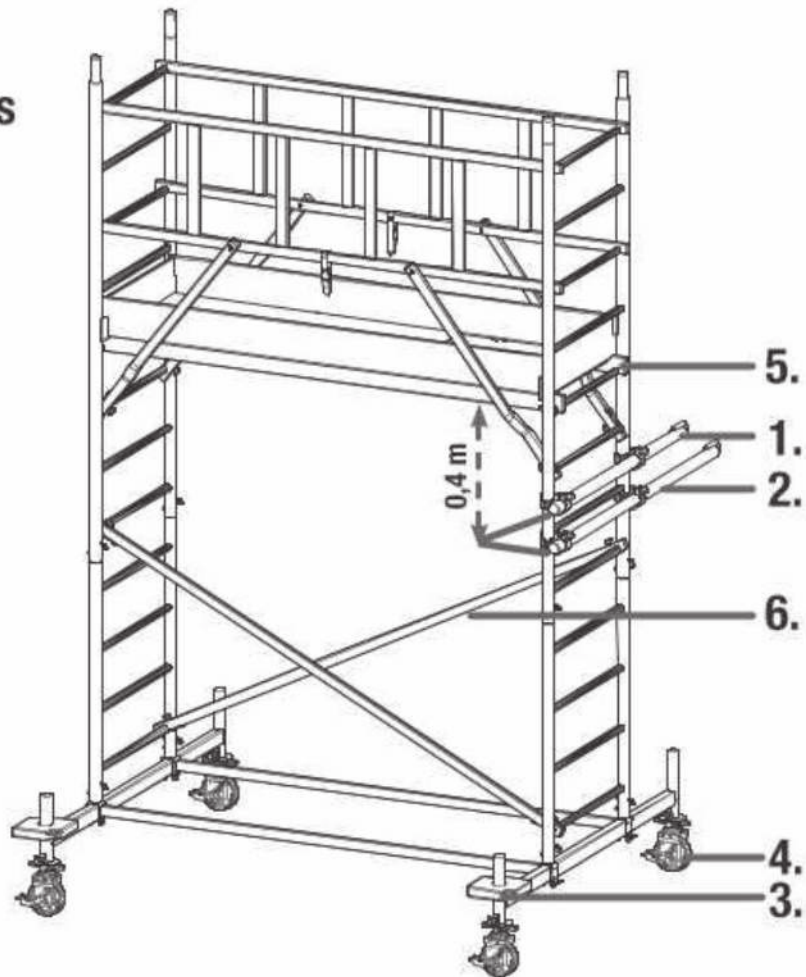

Art.-No.		No.		kg
910059	1,20 m	1		6,9
910066	1,50 m	2		8,4
704306		3		10,0
914118	Ø 150 mm	4		3,8
718853	M5 x 95	5		0,1
912879		6		1,5